

2SP-2500HM Tools

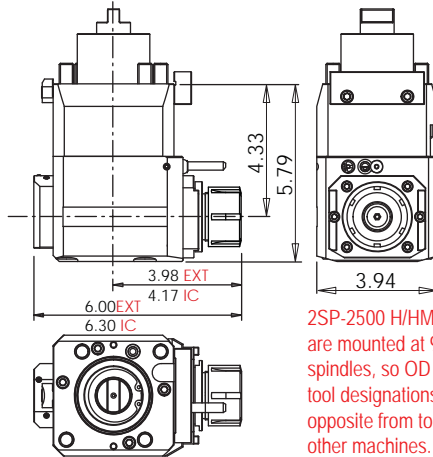

2SP-2500HM Cross Tools • ER-32 Outputs

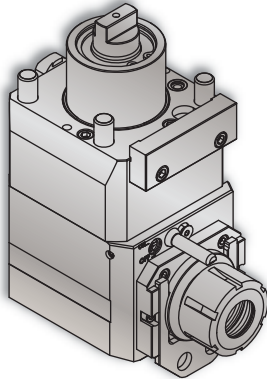

2SP-2500 H/HM turrets are mounted at 90° to spindles, so OD and live tool designations are opposite from tools on other machines.

Notes

Wrenches Included with Tools

Maximum Drill Ø		Maximum Mill Ø	
EXT	13/16"	EXT	23/32"
IC	3/4"	IC	23/32"

Turret Plugs 14.430.0.0086.0

* 1,450 psi internal coolant (IC) cross tool **CAN** be run without coolant; the coolant sealing mechanism can be completely dis-engaged.

All coolant thru live tools require 30 micron coolant filtration nominal, 50 micron coolant filtration absolute.

Tool #	Coolant	Output	Rotation (In:Out)	Ratio (In:Out)	Max. RPM	Torque	Spindle Wrench	Collet Wrench
14.800.0.0472.0	EXT	ER-32	CW:CW	1:1	6,000	60 Nm	Special	7111.32000
14.800.0.0471.0	IC & EXT* 1,450 psi	ERC-32	CW:CW	1:1	6,000	60 Nm	Special	7111.32000

2SP-2500HM Face Tools • ERAX-32 Outputs

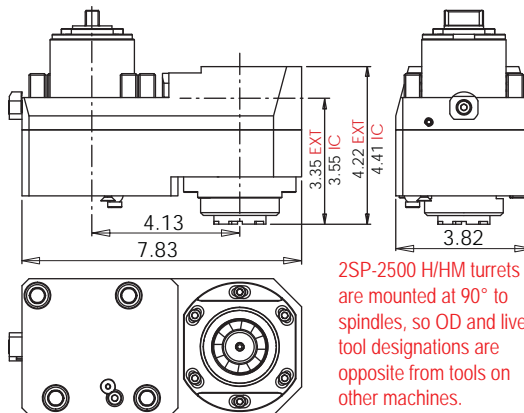
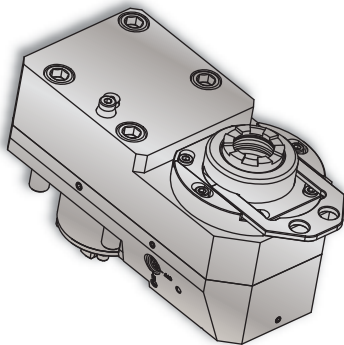

2SP-2500 H/HM turrets are mounted at 90° to spindles, so OD and live tool designations are opposite from tools on other machines.

Notes

Wrenches Included with Tools

Maximum Drill Ø		Maximum Mill Ø	
EXT	13/16"	EXT	23/32"
IC	3/4"	IC	23/32"

Turret Plugs 14.430.0.0086.0

* 1,450 psi internal coolant (IC) face tool **CAN** be run without coolant; the coolant sealing mechanism can be completely dis-engaged.

All coolant thru live tools require 30 micron coolant filtration nominal, 50 micron coolant filtration absolute.

Tool #	Coolant	Output	Rotation (In:Out)	Ratio (In:Out)	Max. RPM	Torque	Spindle Wrench	Collet Wrench
14.101.0.0370.0	EXT	ERAX-32	CW:CW	1:1	6,000	60 Nm	Special	7117.32000
14.101.0.0369.0	IC & EXT* 1,450 psi	ERAXC-32	CW:CW	1:1	6,000	60 Nm	Special	7117.32000