

# VELOCITY TOOLING FOR OKUMA GENOS L300/L3000 BMT

## Live Tools

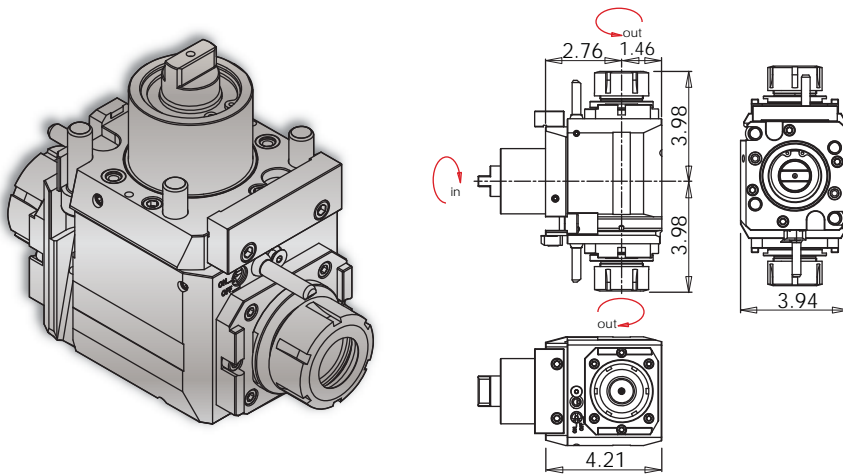

### GENOS L300/L3000 MW • L300 MYW Main/Sub Face Tool • ER-32 Outputs



#### Notes

Wrenches Included with Tools

Maximum Drill Ø	Maximum Mill Ø
13/16"	23/32"
Turret Plugs 14.430.0.0086.0	

VELOCITY/SU-matic driven tools are greased for life and delivered ready to use - **no run-in required**. All driven tools are CMM inspected and internal coolant tools are pressure tested as a final quality check prior to shipment.

Tool #	Coolant	Output	Rotation (In:Out)	Ratio (In:Out)	Max. RPM	Torque	Spindle Wrench	Collet Wrench
14.801.0.0122.0 (14.801.0.0046.0)	EXT	(2) ER-32	See Dwg. Above	1:1	6,000	60 Nm	1005100950	7111.32000

### GENOS L300/L3000 High Speed Face Tool • ER-20 Output

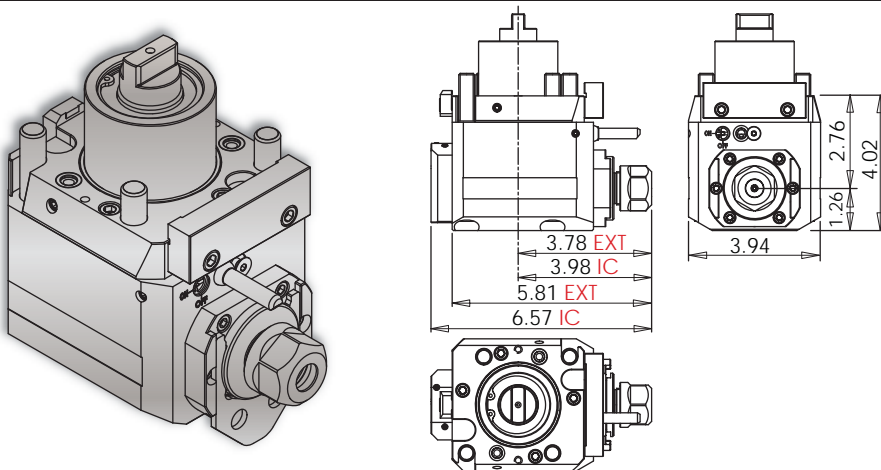

#### Notes

Wrenches Included with Tools

Maximum Drill Ø	Maximum Mill Ø
EXT 1/2"	EXT 15/32"
IC 1/2"	IC 15/32"
Turret Plugs 14.430.0.0086.0	

\* 1,450 psi internal coolant (IC) face tool **CAN** be run without coolant; the coolant sealing mechanism can be completely dis-engaged.

**All coolant thru live tools require 30 micron coolant filtration nominal, 50 micron coolant filtration absolute.**

Tool #	Coolant	Output	Rotation (In:Out)	Ratio (In:Out)	Max. RPM	Torque	Spindle Wrench	Collet Wrench
14.800.0.0429.0	EXT	ER-20	CW:CW	1:2	12,000	12 Nm	Special	7111.20000
14.800.0.0427.0	IC & EXT* 1,450 psi	ERC-20	CW:CW	1:2	12,000	12 Nm	Special	7111.20000