

VELOCITY TOOLING FOR OKUMA LB2000/LB3000 M/MY/MYW

SU-matic Capto® Tools

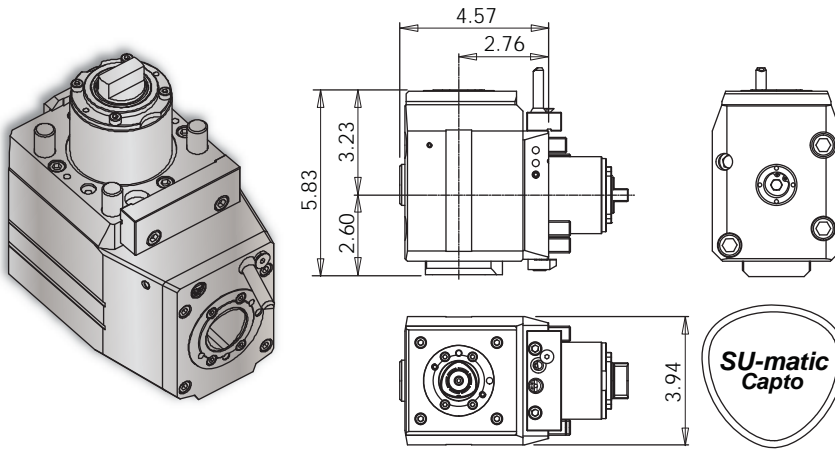

LB2000/LB3000 C4 Face Tool



Notes

REGO-FIX® C4 Collet Chucks

| ER Output | Rego-Fix Part # |
|-----------|-----------------|
| ER-16 | 2804.11630 |
| ER-20 | 2804.12010 |
| ER-25 | 2804.12510 |
| ER-32 | 2804.13210 |

Turret Plugs 14.430.0.0086.0

* 1,450 psi internal coolant (IC) face tool **CAN** be run without coolant; the coolant sealing mechanism can be completely dis-engaged.

All coolant thru live tools require 30 micron coolant filtration nominal, 50 micron coolant filtration absolute.

| Tool # | Coolant | Output | Rotation (In:Out) | Ratio (In:Out) | Max. RPM | Torque | Hex Wrench | C4 Collet Chucks |
|-----------------|------------------------|--------|-------------------|----------------|----------|--------|------------|------------------|
| 14.800.0.0233.1 | IC & EXT* 1,450 psi | C4 | CW:CW | 1:1 | 6,000 | 60 Nm | 10 mm | See Above |

LB2000/LB3000 C4 OD-I Length Turning Holder

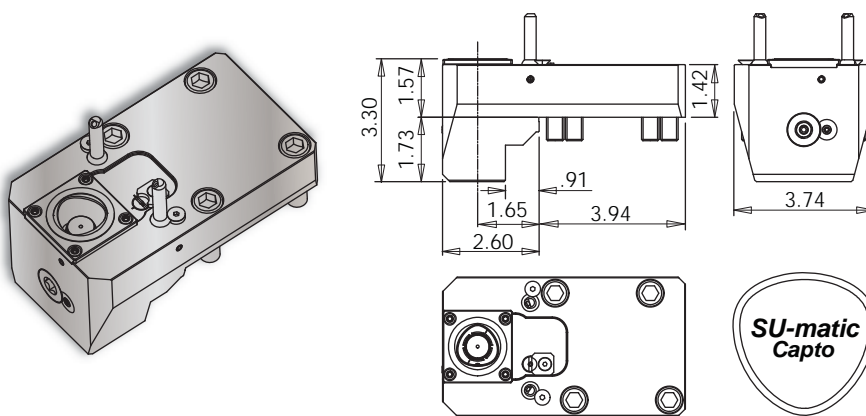

Notes

REGO-FIX® C4 Collet Chucks

| ER Output | Rego-Fix Part # |
|-----------|-----------------|
| ER-16 | 2804.11630 |
| ER-20 | 2804.12010 |
| ER-25 | 2804.12510 |
| ER-32 | 2804.13210 |

Turret Plugs 14.430.0.0086.0

VELOCITY/SU-matic tooling for OKUMA is manufactured on OKUMA machine tools.

SU-matic Capto® static tools are coolant thru. Coolant filtration is recommended.

| Lathe Model | Tool # | Reversible (Main/Sub) | Coolant | Output | Hex Wrench | C4 Collet Chucks |
|-------------|-----------------|-----------------------|---------|--------|------------|------------------|
| LB3000 M | 14.910.0.0239.0 | No | IC/EXT | C4 | 10 mm | See Above |