

VELOCITY TOOLING FOR OKUMA LB2000/LB3000 M/MY/MYW

Live Tools

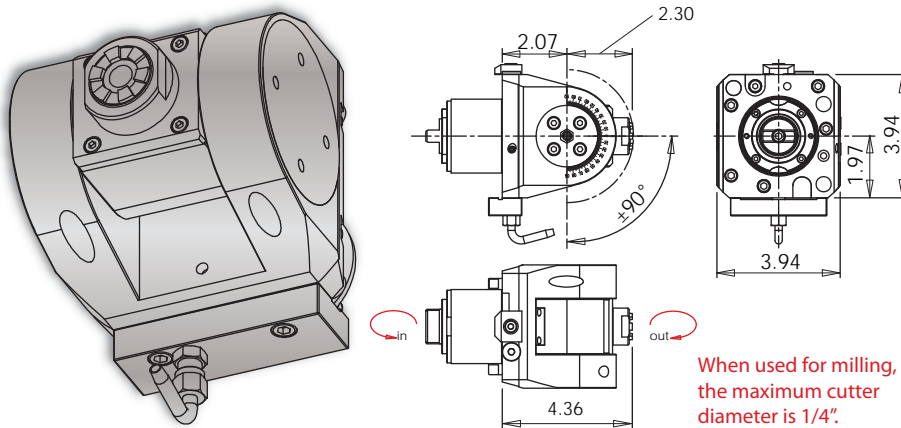

LB2000/LB3000 ±90° Adjustable Angle Tool • ERAX-20 Output



Notes

Wrenches Included with Tools

Maximum Drill Ø	Maximum Mill Ø
1/2"	1/4"
Turret Plugs	14.430.0.0086.0

VELOCITY/SU-matic driven tools are greased for life and delivered ready to use - **no run-in required**. All driven tools are CMM inspected and internal coolant tools are pressure tested as a final quality check prior to shipment.

Tool #	Coolant	Output	Rotation (In:Out)	Ratio (In:Out)	Max. RPM	Torque	Spindle Wrench	Collet Wrench
14.826.0.0015.0	EXT	ERAX-20	CCW:CW	1:1	6,000	15 Nm	32 mm	7117.20000

LB2000/LB3000 Gear Hobbing Tool • 3/4" Arbor

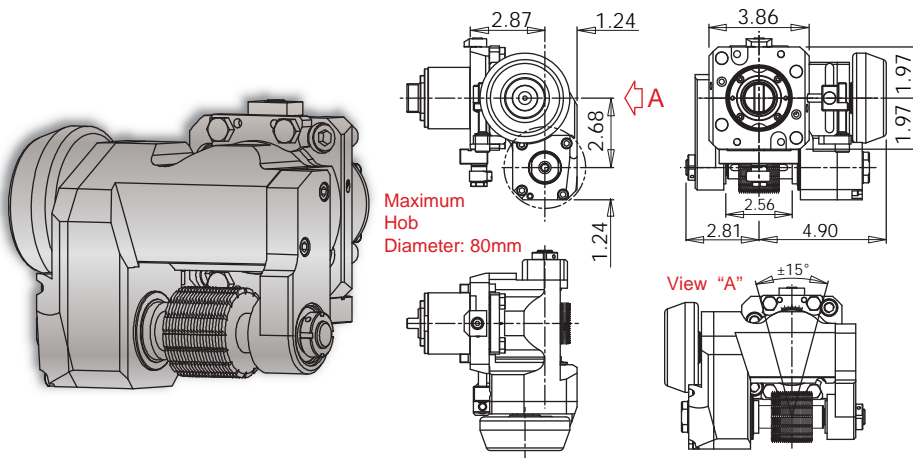

Notes

Wrenches Included with Tools

Maximum Hob Ø	Max. Gear Quality
80 mm	AGMA 7
Turret Plugs	14.430.0.0086.0

VELOCITY/SU-matic driven tools are greased for life and delivered ready to use - **no run-in required**. All driven tools are CMM inspected and internal coolant tools are pressure tested as a final quality check prior to shipment.

Tool #	Coolant	Arbor Diameter	Rotation (In:Out)	Ratio (In:Out)	Max. RPM	Torque	3/4" Arbor
14.800.0.0228.0	EXT	3/4"	CW:CCW	2:1	3,000	50 Nm	14.420.0.0126.0