

# VELOCITY TOOLING FOR OKUMA LT2000 M/MY

## Live Tools

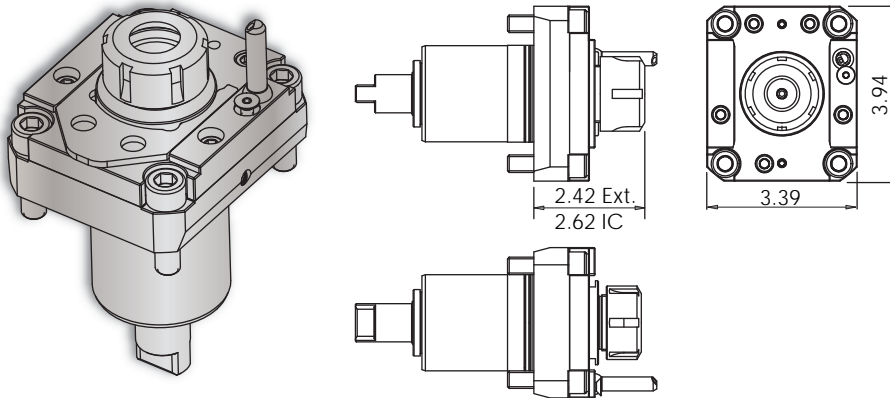

### LT2000 Cross Tools • ER-25 Outputs



### Notes

#### Wrenches Included with Tools

Maximum Drill Ø		Maximum Mill Ø	
EXT	5/8"	EXT	9/16"
IC	5/8"	IC	9/16"

Turret Plugs 14.430.0.0088.0

\* 1,000 psi internal coolant (IC) cross tool **CANNOT** be run without coolant.

**All coolant thru live tools require 30 micron coolant filtration nominal, 50 micron coolant filtration absolute.**

Tool #	Coolant	Output	Rotation (In:Out)	Ratio (In:Out)	Max. RPM	Torque	Spindle Wrench	Collet Wrench
14.101.0.0332.0 (14.101.0.0167.1)	EXT	ER-25	CW:CW	1:1	6,000	40 Nm	1005100930	7111.25000
14.101.0.0331.0 (14.101.0.0166.0)	IC & EXT* 1,000 psi	ERC-25	CW:CW	1:1	6,000	40 Nm	1005100930	7111.25000

### LT2000 High Speed Offset Cross Tools • ERAX-16 Outputs

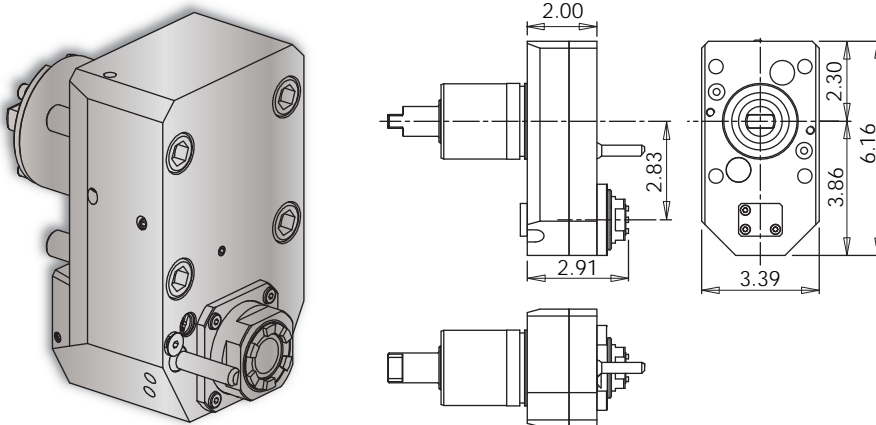

### Notes

#### Wrenches Included with Tools

Maximum Drill Ø	Maximum Mill Ø
13/32"	5/16"

Turret Plugs 14.430.0.0088.0

*VELOCITY/SU-matic* driven tools are greased for life and delivered ready to use - **no run-in required**. All driven tools are CMM inspected and internal coolant tools are pressure tested as a final quality check prior to shipment.

Tool #	Coolant	Output	Rotation (In:Out)	Ratio (In:Out)	Max. RPM	Torque	Spindle Wrench	Collet Wrench
14.101.0.0197.0	EXT	ERAX-16	CW:CW	1:2	12,000	15 Nm	30mm	7117.16000
14.101.0.0190.0	EXT	ERAX-16	CW:CW	1:3	18,000	6 Nm	30mm	7117.16000