

# VELOCITY TOOLING FOR OKUMA LT2000 M/MY

## Live Tools

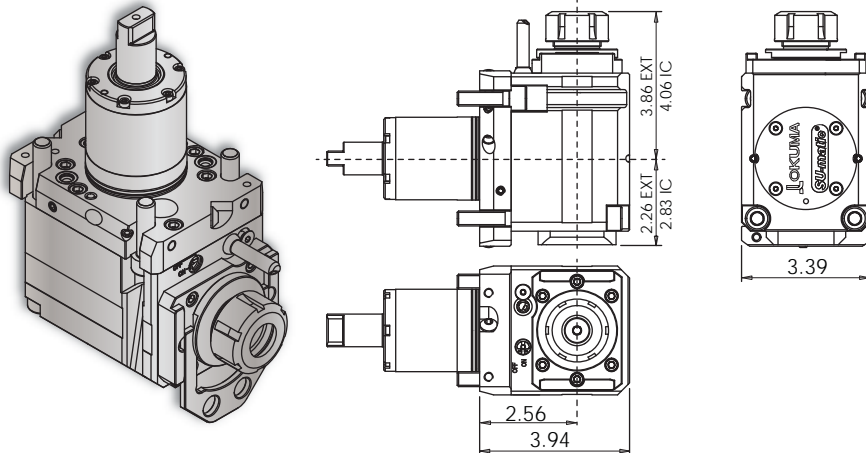

### LT2000 Face Tools • ER-25 Outputs



### Notes

#### Wrenches Included with Tools

Maximum Drill Ø		Maximum Mill Ø	
EXT	5/8"	EXT	9/16"
IC	5/8"	IC	9/16"

Turret Plugs 14.430.0.0088.0

\* 1,450 psi internal coolant (IC) face tool **CAN** be run without coolant; the coolant sealing mechanism can be completely dis-engaged.

All coolant thru live tools require 30 micron coolant filtration nominal, 50 micron coolant filtration absolute.

Tool #	Coolant	Output	Rotation (In:Out)	Ratio (In:Out)	Max. RPM	Torque	Spindle Wrench	Collet Wrench
14.800.0.0433.0 (14.800.0.0273.0)	EXT	ER-25	CW:CW	1:1	6,000	40 Nm	1005100980	7111.25000
14.800.0.0432.0 (14.800.0.0272.0)	IC & EXT* 1,450 psi	ERC-25	CW:CW	1:1	6,000	40 Nm	1005100980	7111.25000

### LT2000 High Speed Face Tools • ER-16 Outputs

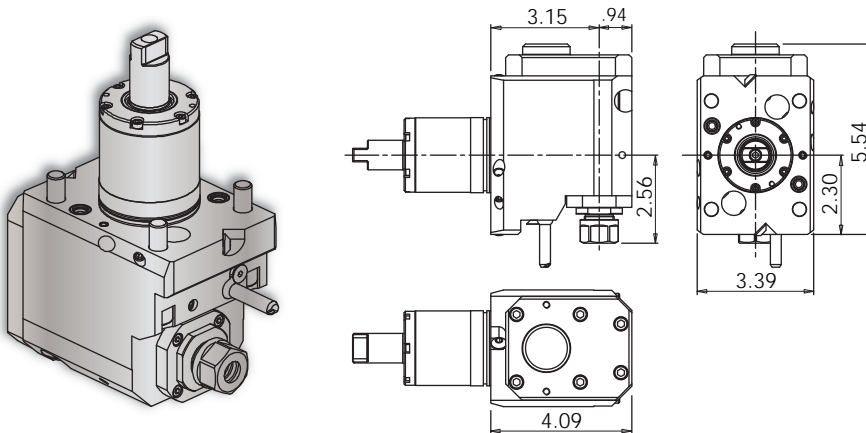

### Notes

#### Wrenches Included with Tools

Maximum Drill Ø	Maximum Mill Ø
13/32"	5/16"

Turret Plugs 14.430.0.0088.0

VELOCITY/SU-matic driven tools are greased for life and delivered ready to use - **no run-in required**. All driven tools are CMM inspected and internal coolant tools are pressure tested as a final quality check prior to shipment.

Tool #	Coolant	Output	Rotation (In:Out)	Ratio (In:Out)	Max. RPM	Torque	Spindle Wrench	Collet Wrench
14.800.0.0309.0	EXT	ER-16	CW:CW	1:2	12,000	10 Nm	48mm	7112.16010
14.800.0.0251.0	EXT	ER-16	CW:CW	1:3	18,000	5 Nm	48mm	7112.16010