

# VELOCITY TOOLING FOR OKUMA LU4000 M/MY

## Hobber • Static Tools



### LU4000 M Gear Hobbing Tool • 3/4" Arbor

### Notes

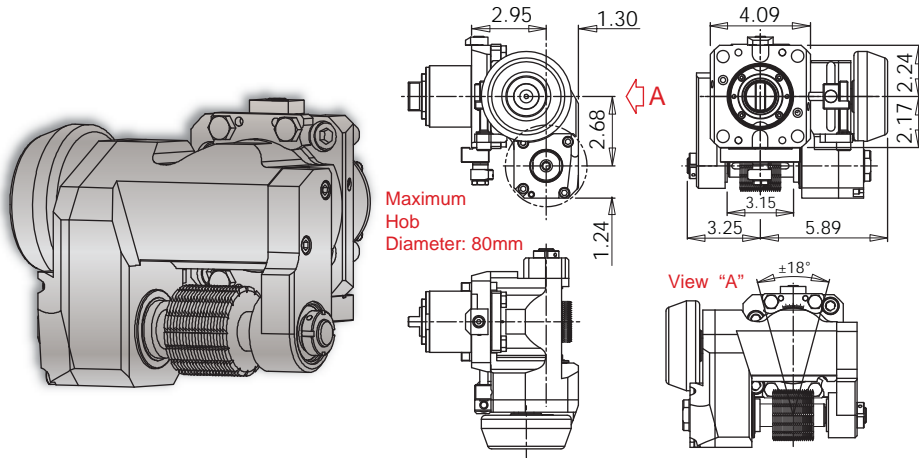

Wrenches Included with Tools

Maximum Hob Ø	Max. Gear Quality
---------------	-------------------

80 mm	AGMA 7
-------	--------

Turret Plugs	14.430.0.0087.0
--------------	-----------------

*VELOCITY/SU-matic* driven tools are greased for life and delivered ready to use - **no run-in required**. All driven tools are CMM inspected and internal coolant tools are pressure tested as a final quality check prior to shipment.

Tool #	Coolant	Arbor Diameter	Rotation (In:Out)	Ratio (In:Out)	Max. RPM	Torque	3/4" Arbor
14.800.0.0258.0	EXT	3/4"	CW:CCW	2:1	3,000	80 Nm	14.420.0.0127.0

### LU4000 M Boring Bar Holder

### Notes

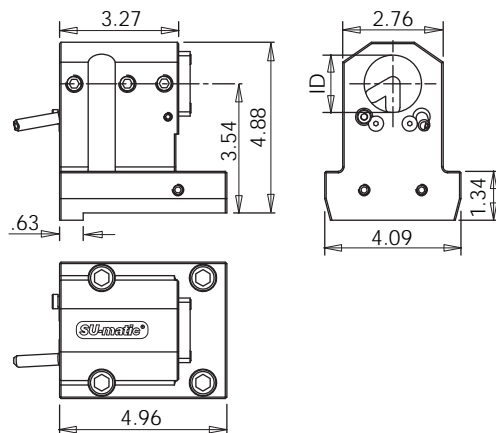
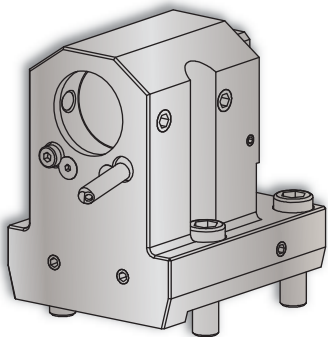

*VELOCITY/SU-matic* ID holders can be used with both internal and external coolant.

Internal Coolant Plates are included with all *VELOCITY/SU-matic* multitasking turret ID holders.

Turret Plugs	14.430.0.0087.0
--------------	-----------------

*VELOCITY/SU-matic* tooling for OKUMA is manufactured on OKUMA machine tools.

Coolant filtration is recommended when using ID holders with internal coolant plates.

Lathe Model	Tool #	Reversible (Main/Sub)	Coolant	ID	Height	Depth (Top)
LU4000 M	14.910.0.0220.0	Yes	IC/EXT	1.5"	4.88"	3.27"