

VELOCITY TOOLING FOR OKUMA LU7000M

SU-matic Capto® Tools

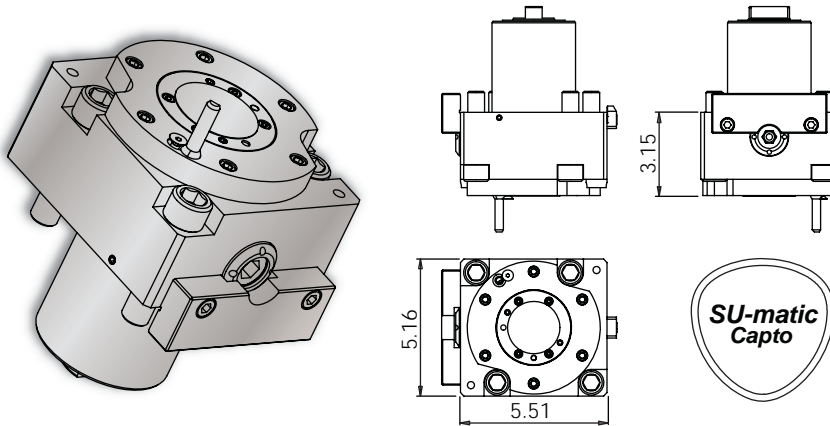

LU7000M C5 Cross Tool



Notes

REGO-FIX® C5 Collet Chucks

ER Output	Rego-Fix Part #
ER-16	4805.11630
ER-20	4805.12010
ER-25	4805.12510
ER-32	4805.13210

Turret Plugs	14.430.0.0157.0
--------------	-----------------

* 1,000 psi internal coolant (IC) cross tool CANNOT be run without coolant.

All coolant thru live tools require 30 micron coolant filtration nominal, 50 micron coolant filtration absolute.

Tool #	Coolant	Output	Rotation (In:Out)	Ratio (In:Out)	Max. RPM	Torque	Hex Wrench	C5 Collet Chucks
14.101.0.0288.0	IC & EXT* 1,000 psi	C5	CW:CW	1:1	3,500	200 Nm	12 mm	See Above

LU7000M C5 Face Tool

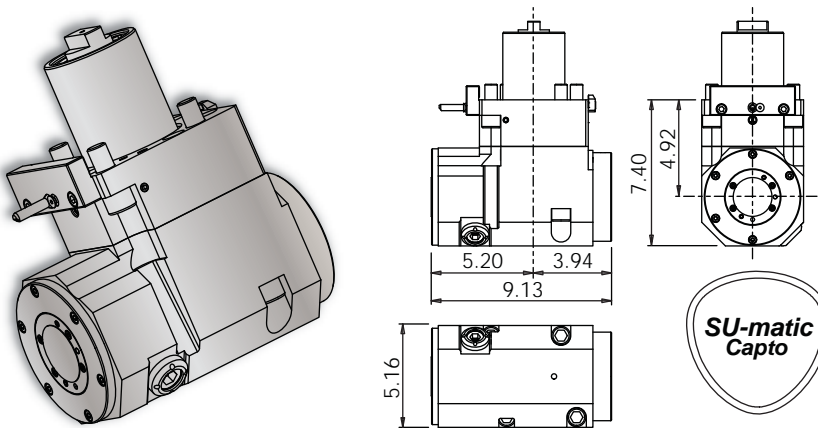

Notes

REGO-FIX® C5 Collet Chucks

ER Output	Rego-Fix Part #
ER-16	4805.11630
ER-20	4805.12010
ER-25	4805.12510
ER-32	4805.13210

Turret Plugs	14.430.0.0157.0
--------------	-----------------

* 1,450 psi internal coolant (IC) face tool CAN be run without coolant; the coolant sealing mechanism can be completely dis-engaged.

All coolant thru live tools require 30 micron coolant filtration nominal, 50 micron coolant filtration absolute.

Tool #	Coolant	Output	Rotation (In:Out)	Ratio (In:Out)	Max. RPM	Torque	Hex Wrench	C5 Collet Chucks
14.800.0.0399.0	IC & EXT* 1,450 psi	C5	CW:CW	1:1	3,500	200 Nm	12 mm	See Above