

VELOCITY TOOLING FOR OKUMA MULTUS U3000/U4000/U5000

Live Tools



Multus U3000/U4000/U5000 Face Tools • ER-32 Output

Notes

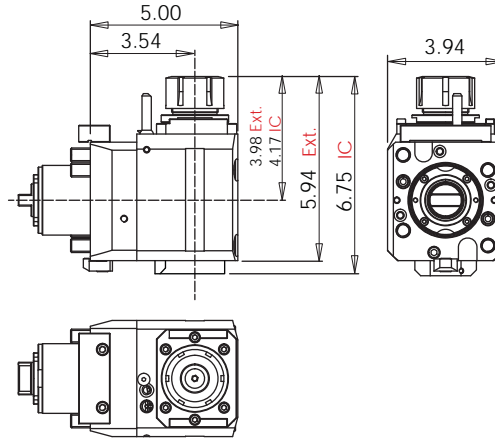
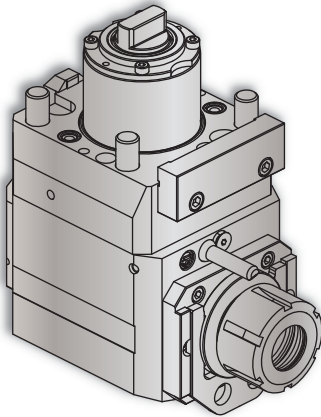

Wrenches Included with Tools

Maximum Drill Ø		Maximum Mill Ø	
EXT	13/16"	EXT	23/32"
IC	3/4"	IC	23/32"

Turret Plugs 14.430.0.0086.0

* 1,450 psi internal coolant (IC) face tool **CAN** be run without coolant; the coolant sealing mechanism can be completely dis-engaged.

All coolant thru live tools require 30 micron coolant filtration nominal, 50 micron coolant filtration absolute.

Tool #	Coolant	Output	Rotation (In:Out)	Ratio (In:Out)	Max. RPM	Torque	Spindle Wrench	Collet Wrench
14.800.0.0366.0	EXT	ER-32	CW:CW	1:1	6,000	60 Nm	1005100950	7111.32000
14.800.0.0367.0	IC & EXT* 1,450 psi	ERC-32	CW:CW	1:1	6,000	60 Nm	1005100950	7111.32000

Multus U3000/U4000/U5000 Main/Sub Spindle Face Tool • ER-32 Outputs

Notes

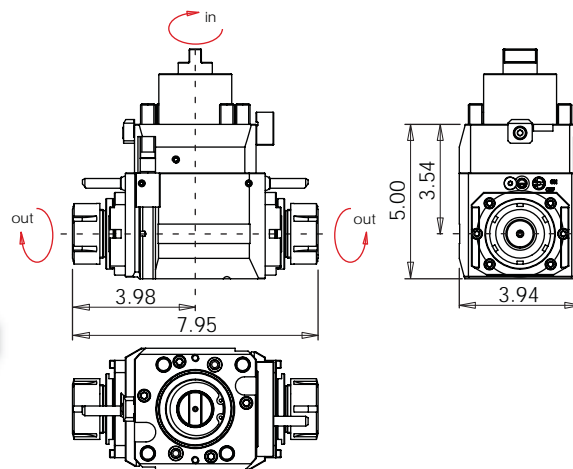
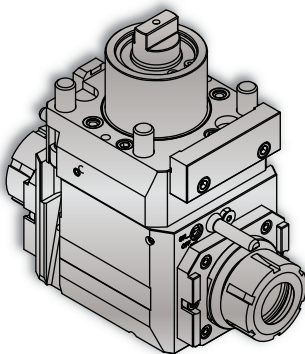

Wrenches Included with Tools

Maximum Drill Ø	Maximum Mill Ø
13/16"	23/32"

Turret Plugs 14.430.0.0086.0

VELOCITY/SU-matic driven tools are greased for life and delivered ready to use - **no run-in required**. All driven tools are CMM inspected and internal coolant tools are pressure tested as a final quality check prior to shipment.

Tool #	Coolant	Output	Rotation (In:Out)	Ratio (In:Out)	Max. RPM	Torque	Spindle Wrench	Collet Wrench
14.801.0.0123.0 (14.801.0.0108.0)	EXT	ER-32	See Dwg. Above	1:1	6,000	60 Nm	1005100950	7111.32000