

V920/2SP-V920 Tools

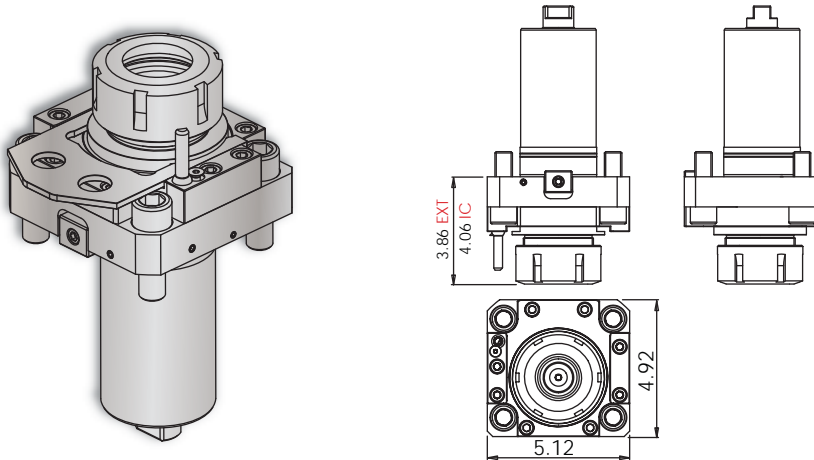

V920 / 2SP-V920 Cross Tools • ER-50 Output



Notes

Wrenches Included with Tools

Maximum Drill Ø		Maximum Mill Ø	
EXT	1 3/8"	EXT	1 3/16"
IC	1 3/8"	IC	1 3/16"

Turret Plugs 14.430.0.0218.0

* 1,000 psi internal coolant (IC) cross tool **CANNOT** be run without coolant.

All coolant thru live tools require 30 micron coolant filtration nominal, 50 micron coolant filtration absolute.

Tool #	Coolant	Output	Rotation (In:Out)	Ratio (In:Out)	Max. RPM	Torque	Spindle Wrench	Collet Wrench
14.101.0.0375.0	EXT	ER-50	CW:CW	1:1	4,000	100 Nm	1005101050	7111.50000
14.101.0.0374.0	IC & EXT* 1,000 psi	ERC-50	CW:CW	1:1	4,000	100 Nm	1005101050	7111.50000

V920 / 2SP-V920 Face Tools • ER-50 Output

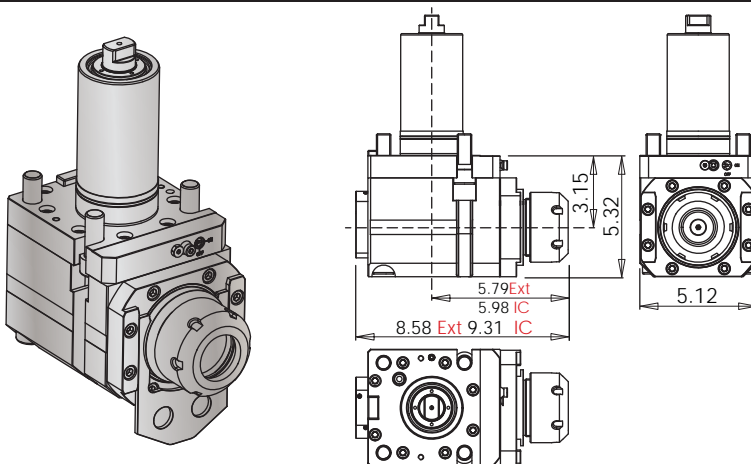

Notes

Wrenches Included with Tools

Maximum Drill Ø		Maximum Mill Ø	
EXT	1 3/8"	EXT	1 3/16"
IC	1 3/8"	IC	1 3/16"

Turret Plugs 14.430.0.0218.0

* 1,450 psi internal coolant (IC) face tool **CAN** be run without coolant; the coolant sealing mechanism can be completely dis-engaged.

All coolant thru live tools require 30 micron coolant filtration nominal, 50 micron coolant filtration absolute.

Tool #	Coolant	Output	Rotation (In:Out)	Ratio (In:Out)	Max. RPM	Torque	Spindle Wrench	Collet Wrench
14.800.0.0479.0	EXT	ER-50	CW:CW	1:1	4,000	100 Nm	1005101050	7111.50000
14.800.0.0478.0	IC & EXT* 1,450 psi	ERC-50	CW:CW	1:1	4,000	100 Nm	1005101050	7111.50000