

# VELOCITY TOOLING FOR OKUMA 2SP-H/2SP-HM Series

## 2SP-2500HM Capto®

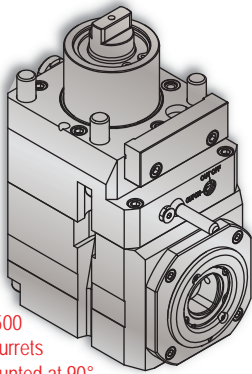

### 2SP-2500HM C4 Cross Tool



2SP-2500 H/HM turrets are mounted at 90° to spindles, so OD and live tool designations are opposite from tools on other machines.

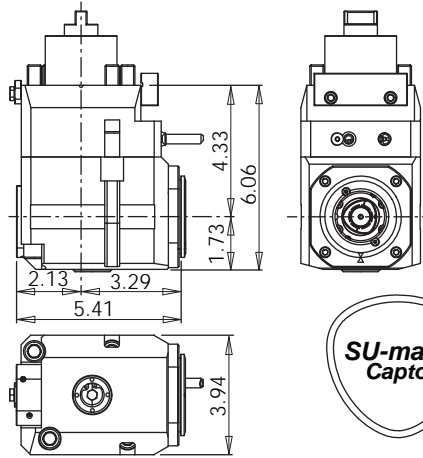

### Notes

#### REGO-FIX® C4 Collet Chucks

ER Output	Rego-Fix Part #
ER-16	2804.11630
ER-20	2804.12010
ER-25	2804.12510
ER-32	2804.13210
Turret Plugs	14.430.0.0086.0

\* 1,000 psi internal coolant (IC) cross tool CANNOT be run without coolant.

All coolant thru live tools require 30 micron coolant filtration nominal, 50 micron coolant filtration absolute.

Tool #	Coolant	Output	Rotation (In:Out)	Ratio (In:Out)	Max. RPM	Torque	Hex Wrench	C4 Collet Chucks
14.800.0.0517.0	IC & EXT* 1,450 psi	C4	CW:CW	1:1	6,000	60 Nm	10 mm	See Above

### 2SP-2500HM C4 Face Tool

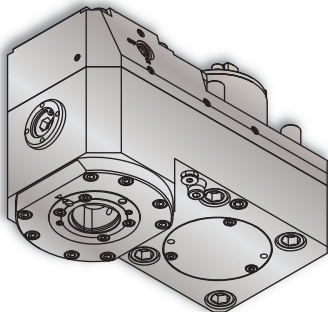

2SP-2500 H/HM turrets are mounted at 90° to spindles, so OD and live tool designations are opposite from tools on other machines.

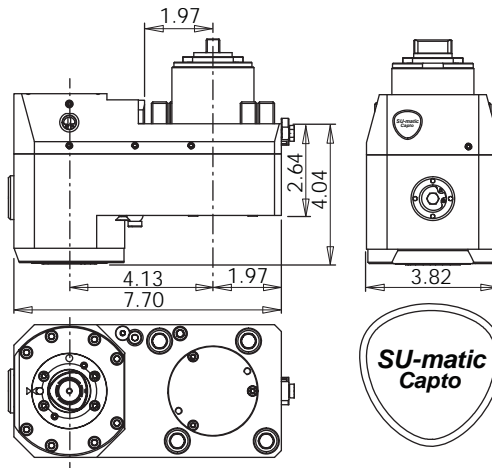

### Notes

#### REGO-FIX® C4 Collet Chucks

ER Output	Rego-Fix Part #
ER-16	2804.11630
ER-20	2804.12010
ER-25	2804.12510
ER-32	2804.13210
Turret Plugs	14.430.0.0086.0

\* 1,450 psi internal coolant (IC) face tool CAN be run without coolant; the coolant sealing mechanism can be completely dis-engaged.

All coolant thru live tools require 30 micron coolant filtration nominal, 50 micron coolant filtration absolute.

Tool #	Coolant	Output	Rotation (In:Out)	Ratio (In:Out)	Max. RPM	Torque	Hex Wrench	C4 Collet Chucks
14.101.0.0395.0	IC & EXT* 1,450 psi	C4	CW:CW	1:2	12,000	20 Nm	10 mm	See Above