

# VELOCITY TOOLING FOR OKUMA 2SP-H/2SP-HM Series

## 2SP-2500H/HM Capto®

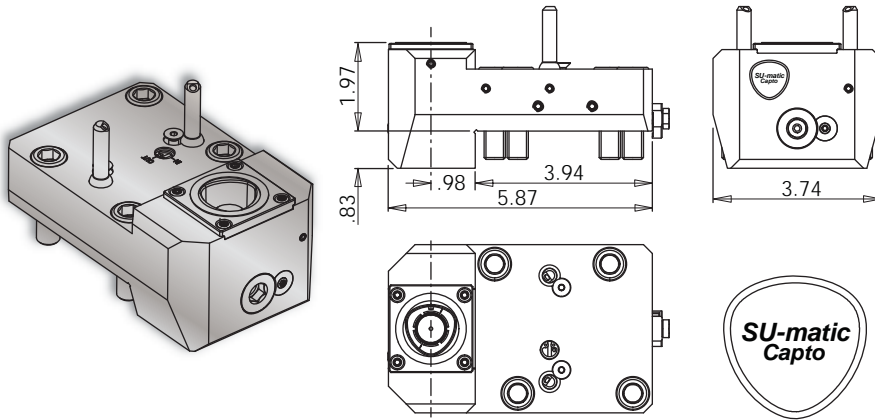

### 2SP-2500H/HM C4 ID Holder



### Notes

#### REGO-FIX® C4 Collet Chucks

ER Output	Rego-Fix Part #
ER-16	2804.11630
ER-20	2804.12010
ER-25	2804.12510
ER-32	2804.13210

Turret Plugs 14.430.0.0086.0

VELOCITY/SU-matic tooling for OKUMA is manufactured on OKUMA machine tools.

SU-matic Capto® static tools are coolant thru. Coolant filtration is recommended.

Tool #	Reversible (Main/Sub)	Coolant	Output	Hex Wrench	C4 Collet Chucks
14.910.0.0525.0	Yes	IC/EXT	C4	10 mm	See Above

### 2SP-2500H/HM C4 OD-I Holder

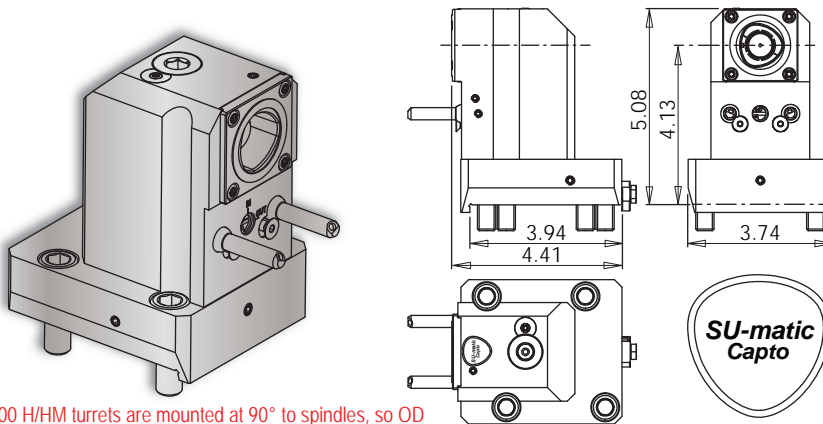

2SP-2500 H/HM turrets are mounted at 90° to spindles, so OD and live tool designations are opposite from tools on other machines.

### Notes

#### REGO-FIX® C4 Collet Chucks

ER Output	Rego-Fix Part #
ER-16	2804.11630
ER-20	2804.12010
ER-25	2804.12510
ER-32	2804.13210

Turret Plugs 14.430.0.0086.0

VELOCITY/SU-matic tooling for OKUMA is manufactured on OKUMA machine tools.

SU-matic Capto® static tools are coolant thru. Coolant filtration is recommended.

Tool #	Reversible (Main/Sub)	Coolant	Output	Hex Wrench	C4 Collet Chucks
14.910.0.0530.0	No	IC/EXT	C4	10 mm	See Above