

# VELOCITY TOOLING FOR OKUMA LB2000/LB3000 M/MY/MYW

## Static Tools



### LB2000 M / LB3000 M Boring Bar Holders

### Notes

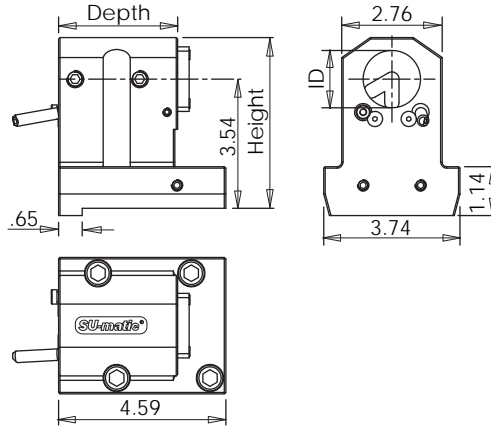
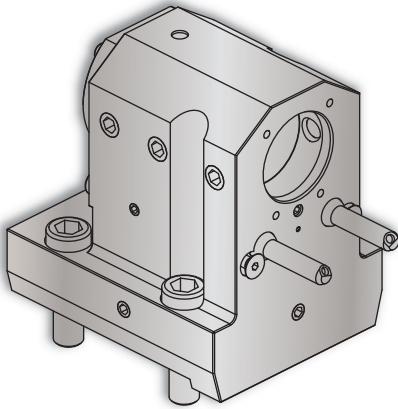

*VELOCITY/SU-matic* ID holders can be used with both internal and external coolant.  
**Internal Coolant Plates** are included with all *VELOCITY/SU-matic* multitasking turret ID holders.

Turret Plugs	14.430.0.0086.0
--------------	-----------------

*VELOCITY/SU-matic* tooling for OKUMA is manufactured on OKUMA machine tools.

Coolant filtration is recommended when using ID holders with internal coolant plates.

Lathe Model	Tool #	Reversible (Main/Sub)	Coolant	ID	Height	Depth (Top)
LB2000 M	14.910.0.0214.0	Yes	IC/EXT	1.25"	4.53"	2.95"
LB3000 M	14.910.0.0208.0	Yes	IC/EXT	1.5"	4.69"	3.27"

### LB3000 M/MY/MYW 1.5" Full Depth Boring Bar Holder

### Notes

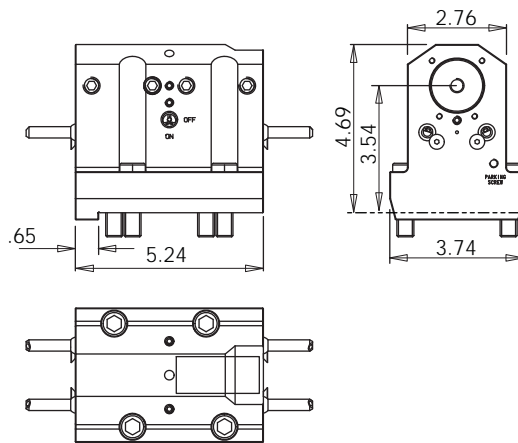
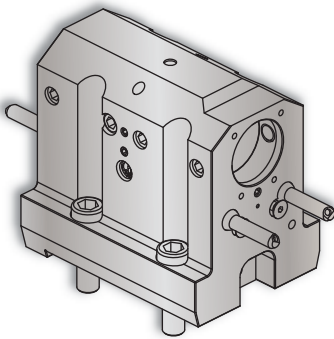

*VELOCITY/SU-matic* ID holders can be used with both internal and external coolant.  
**Internal Coolant Plates** are included with all *VELOCITY/SU-matic* multitasking turret ID holders.

Turret Plugs	14.430.0.0086.0
--------------	-----------------

*VELOCITY/SU-matic* tooling for OKUMA is manufactured on OKUMA machine tools.

Coolant filtration is recommended when using ID holders with internal coolant plates.

Lathe Model	Tool #	Reversible (Main/Sub)	Coolant	ID	Height	Depth
LB3000 M	14.910.0.0376.0	-	IC/EXT	1.5"	4.69"	5.24"