

# VELOCITY TOOLING FOR OKUMA LB45III M-Turret

## Live Tools

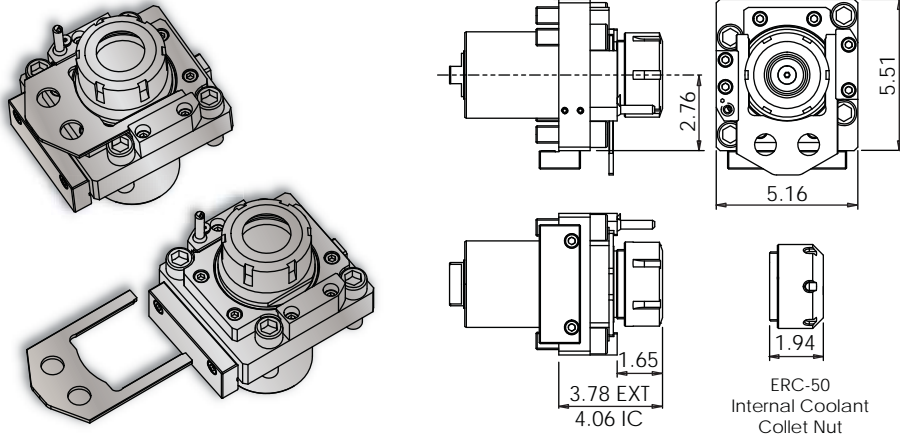

### LB45III M-Turret Cross Tools • ER-50 Output



Notes			
Wrenches Included with Tools			
Maximum Drill Ø		Maximum Mill Ø	
EXT	1 3/8"	EXT	1 3/16"
IC	1 3/8"	IC	1 3/16"
Turret Plugs		14.430.0.0157.0	
* 1,000 psi internal coolant (IC) cross tool <b>CANNOT</b> be run without coolant.			
<b>All coolant thru live tools require 30 micron coolant filtration nominal, 50 micron coolant filtration absolute.</b>			

Tool #	Coolant	Output	Rotation (In:Out)	Ratio (In:Out)	Max. RPM	Torque	Spindle Wrench	Collet Wrench
14.101.0.0279.0	EXT	ER-50	CW:CW	1:1	3,500	200 Nm	1005101050	7111.50000
14.101.0.0277.0	IC & EXT* 1,000 psi	ERC-50	CW:CW	1:1	3,500	200 Nm	1005101050	7111.50000

### LB45III M-Turret Face Tools • ER-50 Output

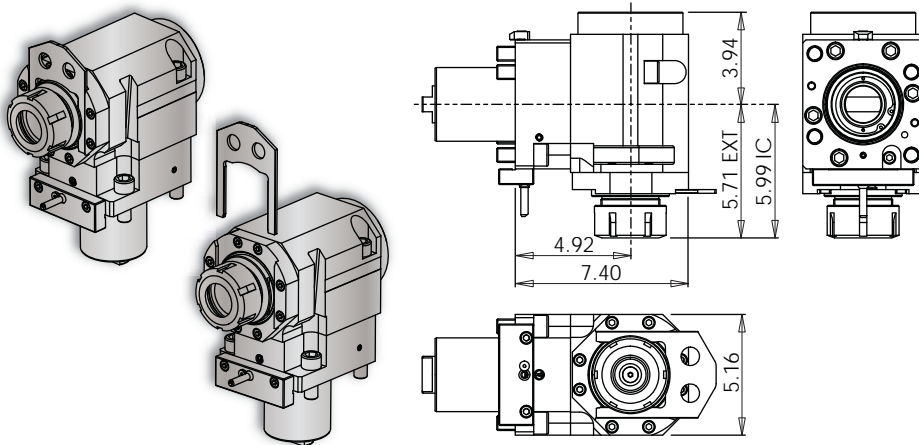

Notes			
Wrenches Included with Tools			
Maximum Drill Ø		Maximum Mill Ø	
EXT	1 3/8"	EXT	1 3/16"
IC	1 3/8"	IC	1 3/16"
Turret Plugs		14.430.0.0157.0	
* 1,450 psi internal coolant (IC) face tool <b>CAN</b> be run without coolant; the coolant sealing mechanism can be completely dis-engaged.			
<b>All coolant thru live tools require 30 micron coolant filtration nominal, 50 micron coolant filtration absolute.</b>			

Tool #	Coolant	Output	Rotation (In:Out)	Ratio (In:Out)	Max. RPM	Torque	Spindle Wrench	Collet Wrench
14.800.0.0395.0	EXT	ER-50	CW:CW	1:1	3,500	200 Nm	1005101050	7111.50000
14.800.0.0393.0	IC & EXT* 1,450 psi	ERC-50	CW:CW	1:1	3,500	200 Nm	1005101050	7111.50000