

VELOCITY TOOLING FOR OKUMA LU4000 M/MY

Live Tools

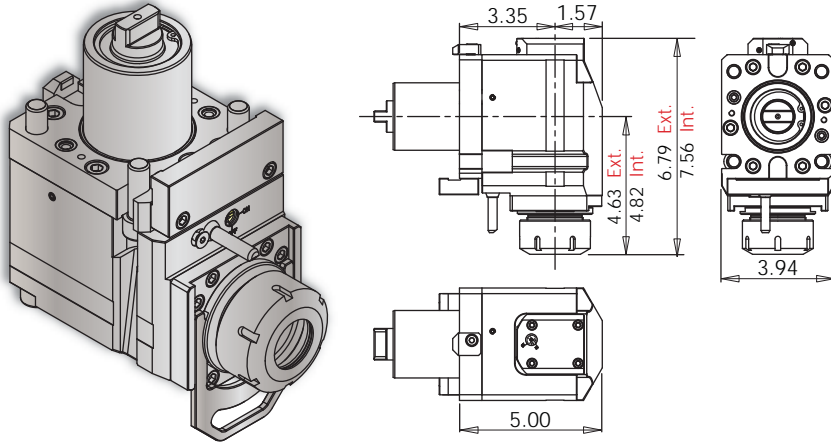

LU4000 M Face Tools • ER-40 Output



Notes

Wrenches Included with Tools

Maximum Drill Ø		Maximum Mill Ø	
EXT	1"	EXT	15/16"
IC	1"	IC	15/16"

Turret Plugs 14.430.0.0087.0

* 1,450 psi internal coolant (IC) face tool **CAN** be run without coolant; the coolant sealing mechanism can be completely dis-engaged.

All coolant thru live tools require 30 micron coolant filtration nominal, 50 micron coolant filtration absolute.

Tool #	Coolant	Output	Rotation (In:Out)	Ratio (In:Out)	Max. RPM	Torque	Spindle Wrench	Collet Wrench
14.800.0.0435.0 (14.800.0.0182.0)	EXT	ER-40	CW:CW	1:1	6,000	85 Nm	1005101120	7111.40000
14.800.0.0434.0 (14.800.0.0216.0)	IC & EXT* 1,450 psi	ERC-40	CW:CW	1:1	6,000	85 Nm	1005101120	7111.40000

LU4000 M ±90° Adjustable Angle Tool • ERAX-25 Output

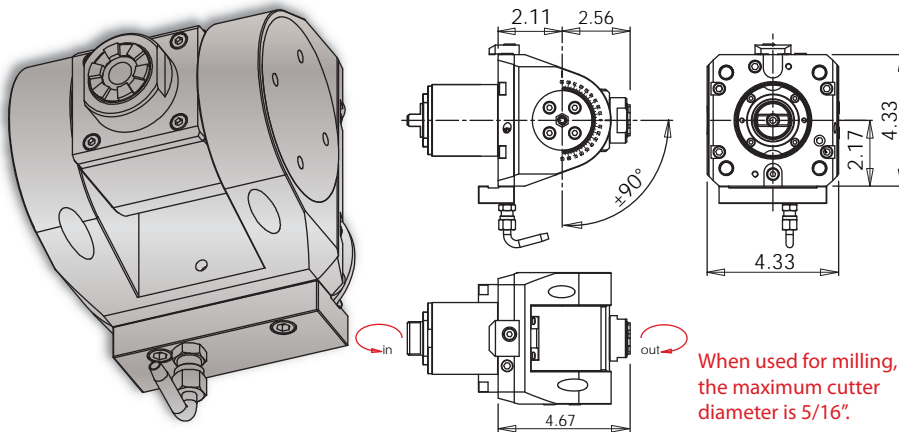

Notes

Wrenches Included with Tools

Maximum Drill Ø	Maximum Mill Ø
5/8"	5/16"

Turret Plugs 14.430.0.0087.0

VELOCITY/SU-matic driven tools are greased for life and delivered ready to use - **no run-in required**. All driven tools are CMM inspected and internal coolant tools are pressure tested as a final quality check prior to shipment.

Tool #	Coolant	Output	Rotation (In:Out)	Ratio (In:Out)	Max. RPM	Torque	Spindle Wrench	Collet Wrench
14.826.0.0017.0	EXT	ERAX-25	CCW:CW	1:1	6,000	25 Nm	36 mm	7117.25000