

# VELOCITY TOOLING FOR OKUMA LU7000M

## Static Tools

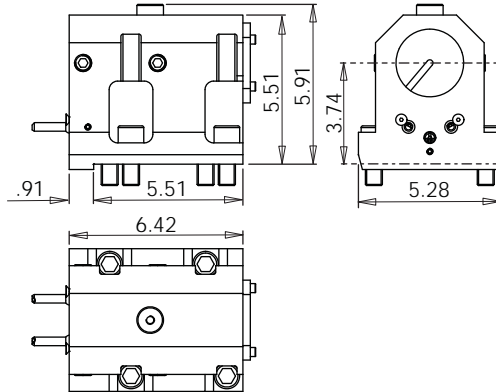

### LU7000M Boring Bar Holder

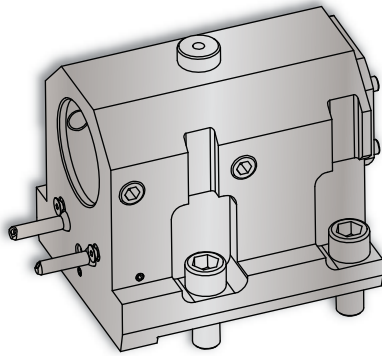

### Notes

*VELOCITY/SU-matic* ID holders can be used with both internal and external coolant.  
**Internal Coolant Plates** are included with all *VELOCITY/SU-matic* multitasking turret ID holders.

Turret Plugs	14.430.0.0157.0
--------------	-----------------

*VELOCITY/SU-matic* tooling for OKUMA is manufactured on OKUMA machine tools.

Coolant filtration is recommended when using ID holders with internal coolant plates.

Lathe Model	Tool #	Reversible (Main/Sub)	Coolant	ID	Height	Depth
LU7000M	14.910.0.0349.0	-	IC/EXT	2.5"	5.51"	6.42"

### LU7000M Split Boring Bar Holder

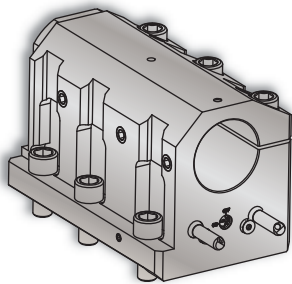

For use on LU7000 M V10 "Wide Turret" Only.

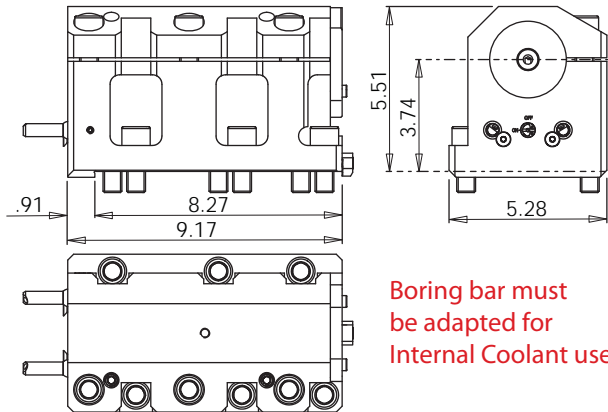

### Notes

*VELOCITY/SU-matic* ID holders can be used with both internal and external coolant.  
**Internal Coolant Plates** are included with all *VELOCITY/SU-matic* multitasking turret ID holders.

Turret Plugs	14.430.0.0157.0
--------------	-----------------

*VELOCITY/SU-matic* tooling for OKUMA is manufactured on OKUMA machine tools.

Coolant filtration is recommended when using ID holders with internal coolant plates.

Lathe Model	Tool #	Reversible (Main/Sub)	Coolant	ID	Height	Depth
LU7000M V10 Wide Turret Only	14.910.0.0522.0	-	IC/EXT	2.5"	5.51"	9.17"