

# VELOCITY TOOLING FOR OKUMA MULTUS U3000/U4000/U5000

## Live Tools

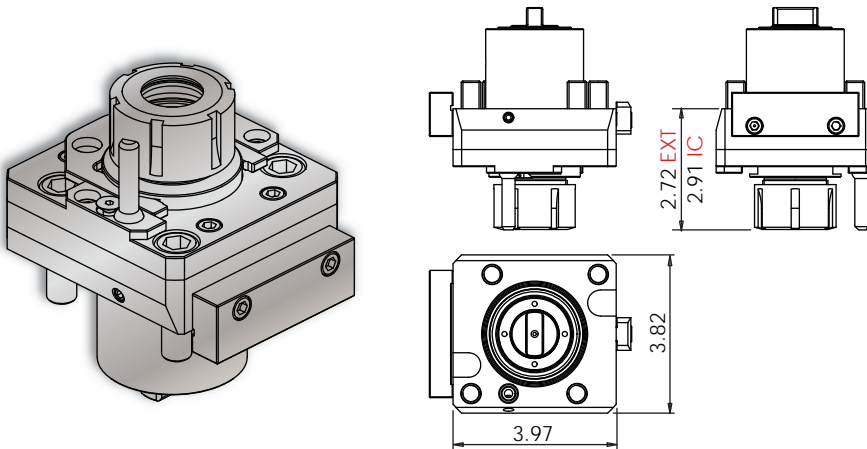

### Multus U3000/U4000/U5000 Cross Tools • ER-32 Output



### Notes

Wrenches Included with Tools

Maximum Drill Ø		Maximum Mill Ø	
EXT	13/16"	EXT	23/32"
IC	3/4"	IC	23/32"

Turret Plugs 14.430.0.0086.0

\* 1,000 psi internal coolant (IC) cross tool CANNOT be run without coolant.

All coolant thru live tools require 30 micron coolant filtration nominal, 50 micron coolant filtration absolute.

Tool #	Coolant	Output	Rotation (In:Out)	Ratio (In:Out)	Max. RPM	Torque	Spindle Wrench	Collet Wrench
14.101.0.0270.0 (14.101.0.0074.0)	EXT	ER-32	CW:CW	1:1	6,000	60 Nm	1005100980	7111.32000
14.101.0.0269.0 (14.101.0.0073.0)	IC & EXT* 1,000 psi	ERC-32	CW:CW	1:1	6,000	60 Nm	1005100980	7111.32000

### Multus U3000/U4000/U5000 Offset Cross Tool • ERAX-25 Output

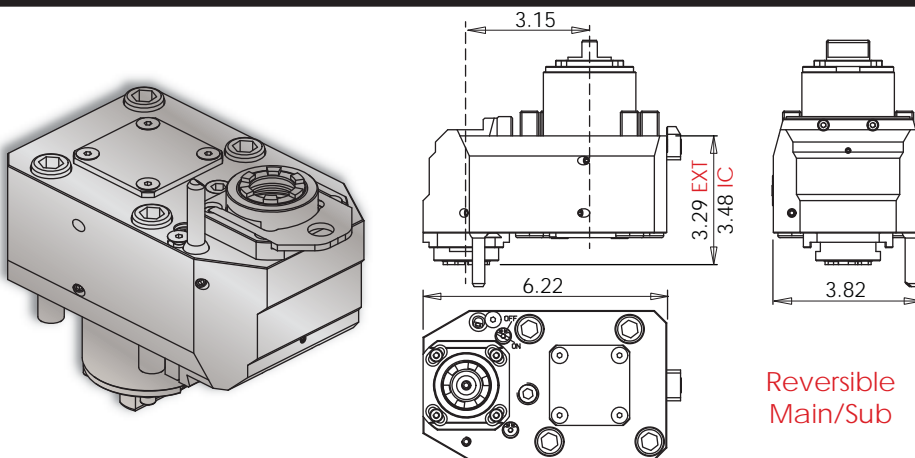

### Notes

Wrenches Included with Tools

Maximum Drill Ø		Maximum Mill Ø	
EXT	5/8"	EXT	17/32"
IC	9/16"	IC	17/32"

Turret Plugs 14.430.0.0086.0

\* 1,000 psi internal coolant (IC) cross tool CANNOT be run without coolant.

All coolant thru live tools require 30 micron coolant filtration nominal, 50 micron coolant filtration absolute.

Tool #	Coolant	Output	Rotation (In:Out)	Ratio (In:Out)	Max. RPM	Torque	Spindle Wrench	Collet Wrench
14.101.0.0287.0	EXT	ERAX-25	CW:CW	1:1	6,000	40 Nm	Special	7117.25000
14.101.0.0146.1	IC & EXT* 1,000 psi	ERAXC-25	CW:CW	1:1	6,000	40 Nm	Special	7117.25000