

# VELOCITY TOOLING FOR OKUMA V760/V920•2SP-V760/V920

## SU-matic Capto® Tools

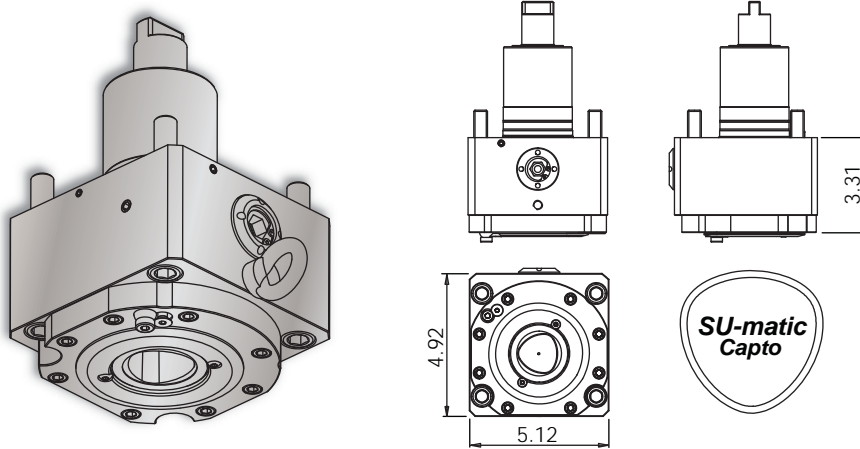

### V920 / 2SP-V920 C5 Cross Tool



### Notes

#### REGO-FIX® C5 Collet Chucks

ER Output	Rego-Fix Part #
ER-16	4805.11630
ER-20	4805.12010
ER-25	4805.12510
ER-32	4805.13210
Turret Plugs	14.430.0.0218.0

\* 1,000 psi internal coolant (IC) cross tool CANNOT be run without coolant.

All coolant thru live tools require 30 micron coolant filtration nominal, 50 micron coolant filtration absolute.

Tool #	Coolant	Output	Rotation (In:Out)	Mounting Bolts	Max. RPM	Torque	Hex Wrench	C5 Collet Chucks
14.101.0.0378.0	IC & EXT* 1,000 psi	C5	CW:CW	M16	4,000	100 Nm	12 mm	See Above

### V920 / 2SP-V920 C5 Face Tool

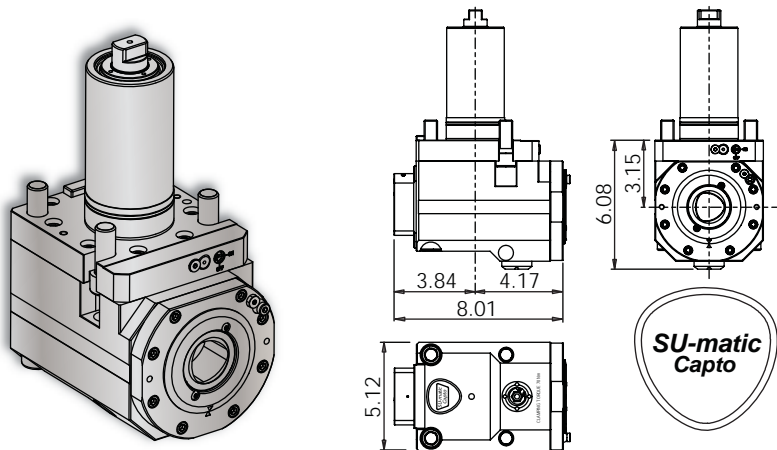

### Notes

#### REGO-FIX® C5 Collet Chucks

ER Output	Rego-Fix Part #
ER-16	4805.11630
ER-20	4805.12010
ER-25	4805.12510
ER-32	4805.13210
Turret Plugs	14.430.0.0218.0

\* 1,450 psi internal coolant (IC) face tool CAN be run without coolant; the coolant sealing mechanism can be completely dis-engaged.

All coolant thru live tools require 30 micron coolant filtration nominal, 50 micron coolant filtration absolute.

Tool #	Coolant	Output	Rotation (In:Out)	Mounting Bolts	Max. RPM	Torque	Hex Wrench	C5 Collet Chucks
14.800.0.0488.0	IC & EXT* 1,450 psi	C5	CW:CW	M16	4,000	100 Nm	12 mm	See Above