

# Quick Change Tools



## LB2000/LB3000 MY C4 Y-Axis OD-I Length Turning Holder

### Notes

#### REGO-FIX® C4 Collet Chucks

ER Output	Rego-Fix Part #
ER-16	2804.11630
ER-20	2804.12010
ER-25	2804.12510
ER-32	2804.13210

Turret Plugs V01-D0-0511

VELOCITY tooling for OKUMA is manufactured on OKUMA machine tools.

Quick Change static tools are coolant thru. Coolant filtration is recommended.

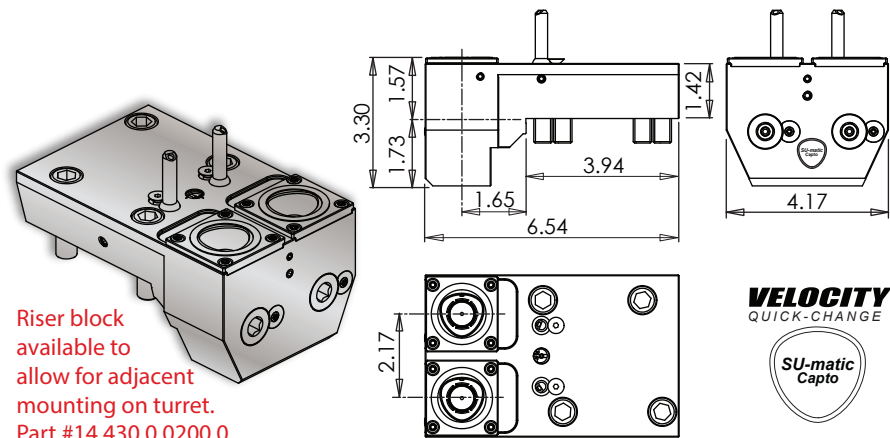

Riser block available to allow for adjacent mounting on turret. Part #14.430.0.0200.0



Lathe Model	Tool #	Reversible (Main/Sub)	Coolant	Output	Hex Wrench	C4 Collet Chucks
LB3000 MY	14.910.0.0118.0	No	IC/EXT	(2) C4	10 mm	See Above

## LB2000/LB3000 MYW C4 Double OD-I-S Length Turning Holder

### Notes

#### REGO-FIX® C4 Collet Chucks

ER Output	Rego-Fix Part #
ER-16	2804.11630
ER-20	2804.12010
ER-25	2804.12510
ER-32	2804.13210

Turret Plugs V01-D0-0511

VELOCITY tooling for OKUMA is manufactured on OKUMA machine tools.

Quick Change static tools are coolant thru. Coolant filtration is recommended.

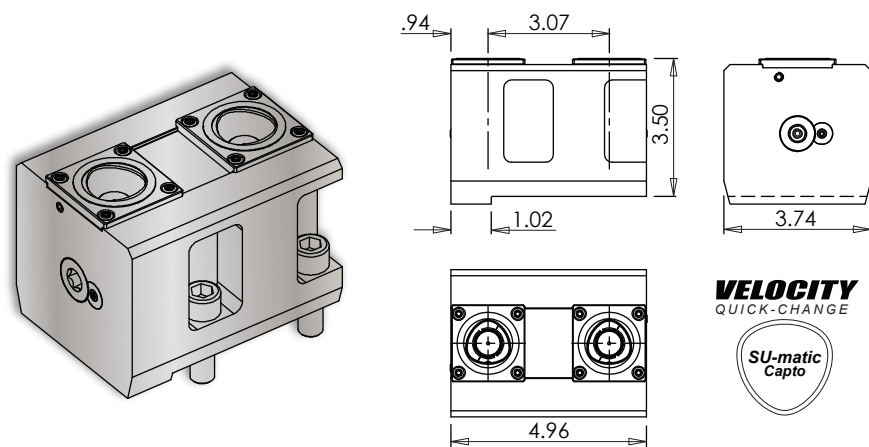

Lathe Model	Tool #	Reversible (Main/Sub)	Coolant	Output	Hex Wrench	C4 Collet Chucks
LB3000 MYW	14.910.0.0043.0	No	IC/EXT	(2) C4	10 mm	See Above

# Quick Change Tools



## LB2000/LB3000 C4 Boring Bar Holder

### Notes

#### REGO-FIX® C4 Collet Chucks

ER Output	Rego-Fix Part #
ER-16	2804.11630
ER-20	2804.12010
ER-25	2804.12510
ER-32	2804.13210

Turret Plugs V01-D0-0511

VELOCITY tooling for OKUMA is manufactured on OKUMA machine tools.

Quick Change static tools are coolant thru. Coolant filtration is recommended.

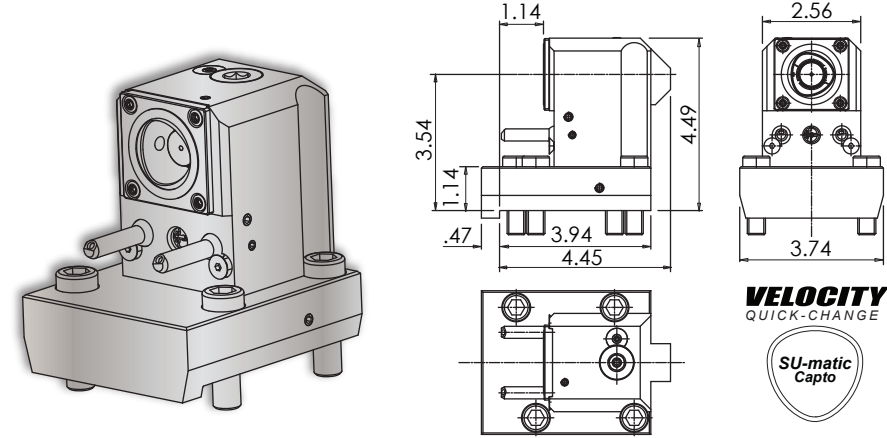

Lathe Model	Tool #	Reversible (Main/Sub)	Coolant	Output	Hex Wrench	C4 Collet Chucks
LB3000 M	14.910.0.0237.0	Yes	IC/EXT	C4	10 mm	See Above

## LB3000EX-MYW/800 C4 Boring Bar Holder

### Notes

#### REGO-FIX® C4 Collet Chucks

ER Output	Rego-Fix Part #
ER-16	2804.11630
ER-20	2804.12010
ER-25	2804.12510
ER-32	2804.13210

Turret Plugs V01-D0-0511

VELOCITY tooling for OKUMA is manufactured on OKUMA machine tools.

Quick Change static tools are coolant thru. Coolant filtration is recommended.

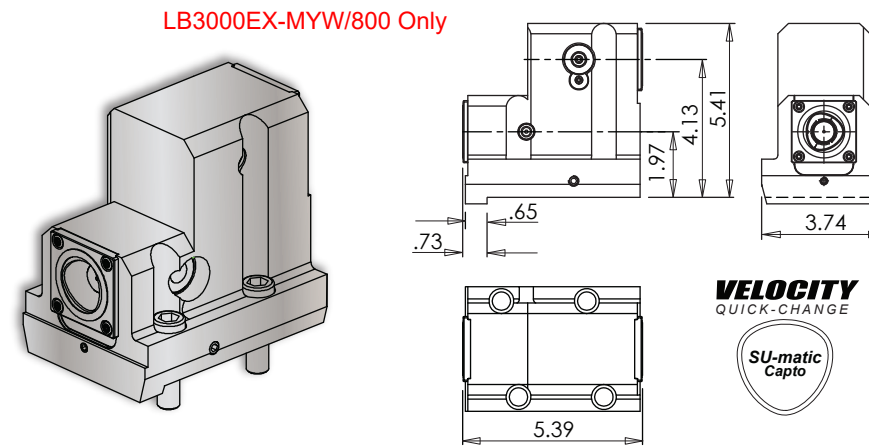

Lathe Model	Tool #	Reversible (Main/Sub)	Coolant	Output	Hex Wrench	C4 Collet Chucks
LB3000 MW	14.910.0.0044.0	Yes	IC/EXT	(2) C4	10 mm	See Above



VELOCITYPRODUCTS.COM



VELOCITYPRODUCTS.COM