

# VELOCITY TOOLING FOR OKUMA LU3000 M/MY

## SU-matic Capto® Tools

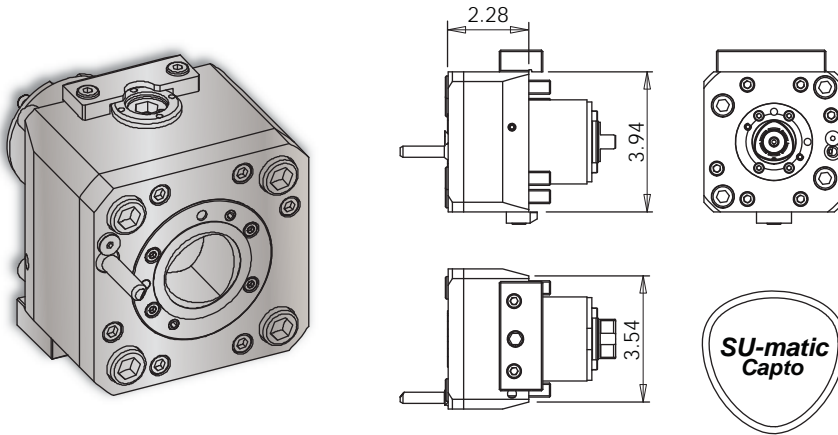

### LU3000 C4 Cross Tool



### Notes

#### REGO-FIX® C4 Collet Chucks

ER Output	Rego-Fix Part #
ER-16	2804.11630
ER-20	2804.12010
ER-25	2804.12510
ER-32	2804.13210

Turret Plugs	14.430.0.0086.0
--------------	-----------------

\* 1,000 psi internal coolant (IC) cross tool CANNOT be run without coolant.

All coolant thru live tools require 30 micron coolant filtration nominal, 50 micron coolant filtration absolute.

Tool #	Coolant	Output	Rotation (In:Out)	Ratio (In:Out)	Max. RPM	Torque	Hex Wrench	C4 Collet Chucks
14.101.0.0325.0 (14.101.0.0138.1)	IC & EXT* 1,000 psi	C4	CW:CW	1:1	6,000	60 Nm	10 mm	See Above

### LU3000 C5 Cross Tool

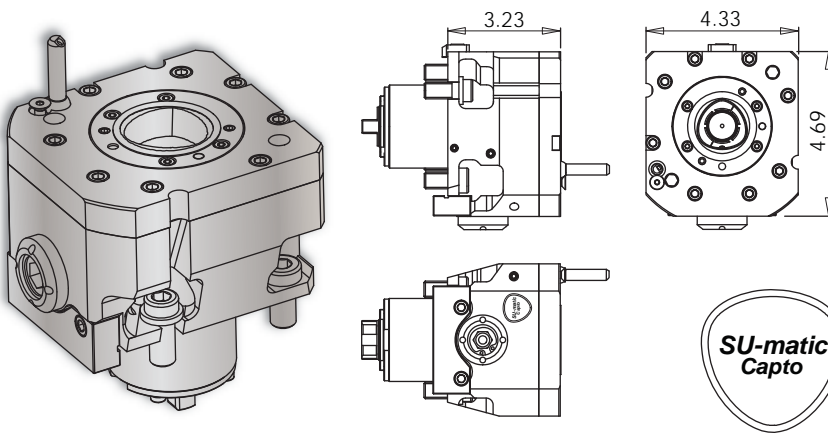

### Notes

#### REGO-FIX® C5 Collet Chucks

ER Output	Rego-Fix Part #
ER-16	4805.11630
ER-20	2805.12010
ER-25	2805.12510
ER-32	2805.13210

Turret Plugs	14.430.0.0086.0
--------------	-----------------

\* 1,000 psi internal coolant (IC) cross tool CANNOT be run without coolant.

All coolant thru live tools require 30 micron coolant filtration nominal, 50 micron coolant filtration absolute.

Tool #	Coolant	Output	Rotation (In:Out)	Ratio (In:Out)	Max. RPM	Torque	Hex Wrench	C5 Collet Chucks
14.101.0.0316.0	IC & EXT* 1,000 psi	C5	CW:CW	1:1	6,000	60 Nm	10 mm	See Above