

VELOCITY TOOLING FOR OKUMA GENOS L300/L3000 BMT

Live Tools

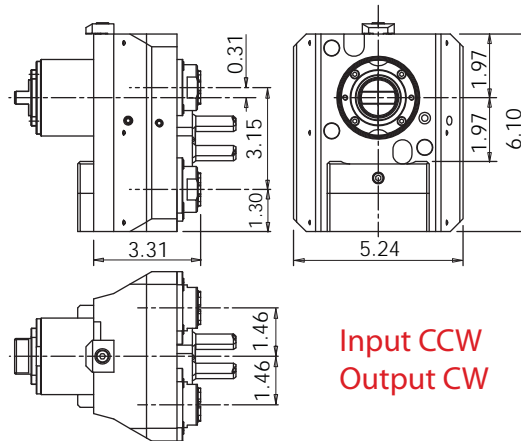

GENOS L300 MYW Offset Quad Cross Tool • ERAX-16 Outputs

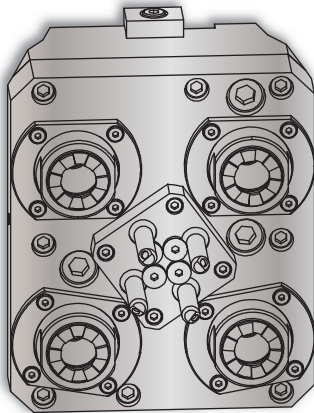

Notes

Wrenches Included with Tools

Maximum Drill Ø	Maximum Mill Ø
13/32"	5/16"
Turret Plugs 14.430.0.0086.0	

VELOCITY/SU-matic driven tools are greased for life and delivered ready to use - **no run-in required**. All driven tools are CMM inspected and internal coolant tools are pressure tested as a final quality check prior to shipment.

Tool #	Coolant	Output	Rotation (In:Out)	Ratio (In:Out)	Max. RPM	Torque	Spindle Wrench	Collet Wrench
14.101.0.0164.0	EXT	(4) ERAX-16	CCW: CW	1:1	6,000	35 Nm	32 mm	7117.16000

GENOS L300/L3000 Face Tools • ER-32 Output

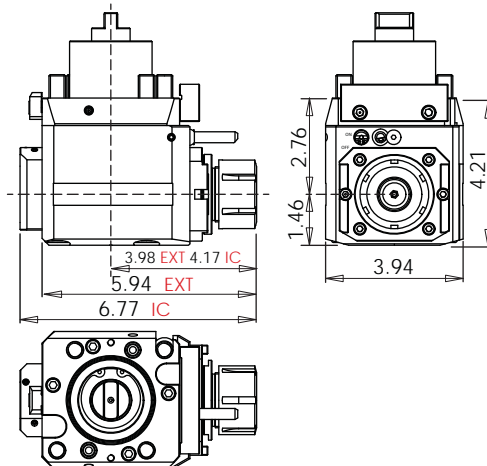
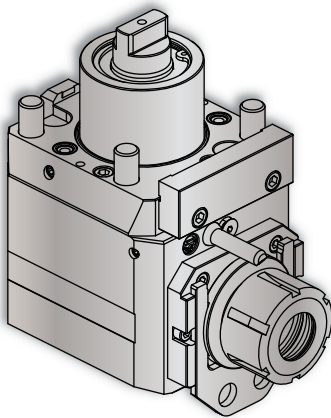

Notes

Wrenches Included with Tools

Maximum Drill Ø	Maximum Mill Ø
EXT 13/16"	EXT 23/32"
IC 3/4"	IC 23/32"
Turret Plugs 14.430.0.0086.0	

* 1,450 psi internal coolant (IC) face tool **CAN** be run without coolant; the coolant sealing mechanism can be completely dis-engaged.

All coolant thru live tools require 30 micron coolant filtration nominal, 50 micron coolant filtration absolute.

Tool #	Coolant	Output	Rotation (In:Out)	Ratio (In:Out)	Max. RPM	Torque	Spindle Wrench	Collet Wrench
14.800.0.0379.0 (14.800.0.0176.0)	EXT	ER-32	CW: CW	1:1	6,000	60 Nm	1005100950	7111.32000
14.800.0.0378.0 (14.800.0.0213.0)	IC & EXT* 1,450 psi	ERC-32	CW: CW	1:1	6,000	60 Nm	1005100950	7111.32000