

VELOCITY TOOLING FOR OKUMA LT2000 M/MY

SU-matic Capto® Tools

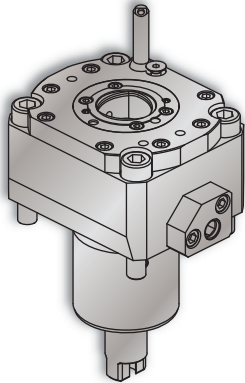

LT2000 C4 Cross Tool • Standard Turret Only



For use with standard turret

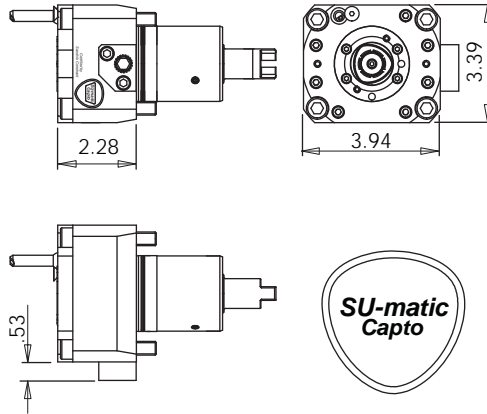

Notes

REGO-FIX® C4 Collet Chucks

ER Output	Rego-Fix Part #
ER-16	2804.11630
ER-20	2804.12010
ER-25	2804.12510
ER-32	2804.13210

Turret Plugs	14.430.0.0088.0
--------------	-----------------

* 1,450 psi internal coolant (IC) face tool **CAN** be run without coolant; the coolant sealing mechanism can be completely dis-engaged.

All coolant thru live tools require 30 micron coolant filtration nominal, 50 micron coolant filtration absolute.

Tool #	Coolant	Output	Rotation (In:Out)	Ratio (In:Out)	Max. RPM	Torque	Hex Wrench	C4 Collet Chucks
14.101.0.0327.0 (14.101.0.0241.1)	IC & EXT* 1,000 psi	C4	CW:CW	1:1	6,000	40 Nm	10 mm	See Above

LT2000 C4 Cross Tool • Modified Turret Only

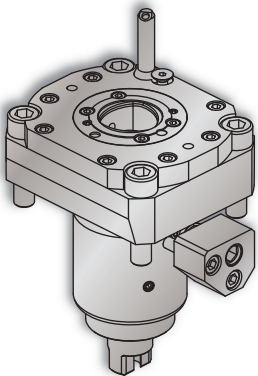

Low profile tool - only for use with modified turret

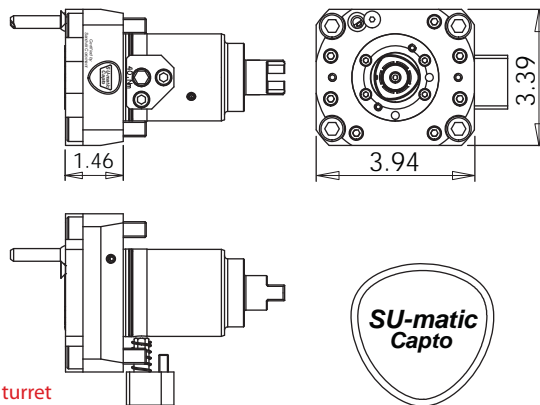

Notes

REGO-FIX® C4 Collet Chucks

ER Output	Rego-Fix Part #
ER-16	2804.11630
ER-20	2804.12010
ER-25	2804.12510
ER-32	2804.13210

Turret Plugs	14.430.0.0088.0
--------------	-----------------

* 1,000 psi internal coolant (IC) cross tool **CANNOT** be run without coolant.

All coolant thru live tools require 30 micron coolant filtration nominal, 50 micron coolant filtration absolute.

Tool #	Coolant	Output	Rotation (In:Out)	Ratio (In:Out)	Max. RPM	Torque	Hex Wrench	C4 Collet Chucks
14.101.0.0187.1	IC & EXT* 1,000 psi	C4	CW:CW	1:1	6,000	40 Nm	10 mm	See Above