

# VELOCITY TOOLING FOR OKUMA LT2000 M/MY

## SU-matic Capto® Tools

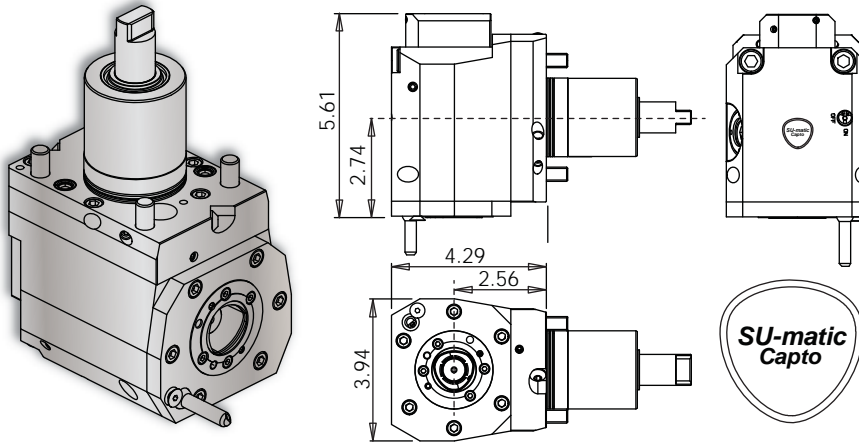

### LT2000 C4 Face Tool



### Notes

#### REGO-FIX® C4 Collet Chucks

ER Output	Rego-Fix Part #
ER-16	2804.11630
ER-20	2804.12010
ER-25	2804.12510
ER-32	2804.13210
Turret Plugs	14.430.0.0088.0

\* 1,450 psi internal coolant (IC) face tool **CAN** be run without coolant; the coolant sealing mechanism can be completely dis-engaged.

All coolant thru live tools require 30 micron coolant filtration nominal, 50 micron coolant filtration absolute.

Tool #	Coolant	Output	Rotation (In:Out)	Ratio (In:Out)	Max. RPM	Torque	Hex Wrench	C4 Collet Chucks
14.800.0.0293.1	IC & EXT* 1,450 psi	C4	CW: CW	1:1	6,000	40 Nm	10 mm	See Above

### LT2000 C4 Dual Output Face Tool (L / R Spindles)

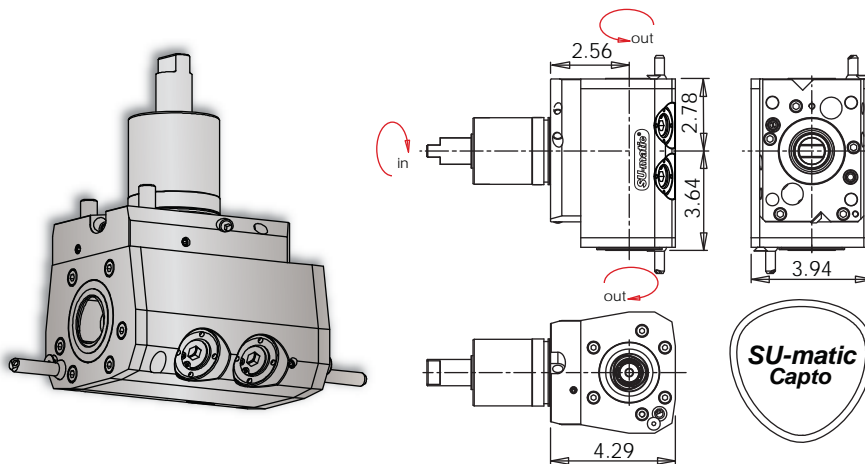

### Notes

#### REGO-FIX® C4 Collet Chucks

ER Output	Rego-Fix Part #
ER-16	2804.11630
ER-20	2804.12010
ER-25	2804.12510
ER-32	2804.13210
Turret Plugs	14.430.0.0088.0

VELOCITY/SU-matic driven tools are greased for life and delivered ready to use - **no run-in required**. All driven tools are CMM inspected.

Tool #	Coolant	Output	Rotation (In:Out)	Ratio (In:Out)	Max. RPM	Torque	Hex Wrench	C4 Collet Chucks
14.801.0.0088.0	EXT	C4	See Drawing Above	1:1	6,000	40 Nm	10 mm	See Above