

# VELOCITY TOOLING FOR OKUMA 2SP-H/2SP-HM Series

## 2SP-150HM Capto®



### 2SP-150HM C4 Cross Tool

### Notes

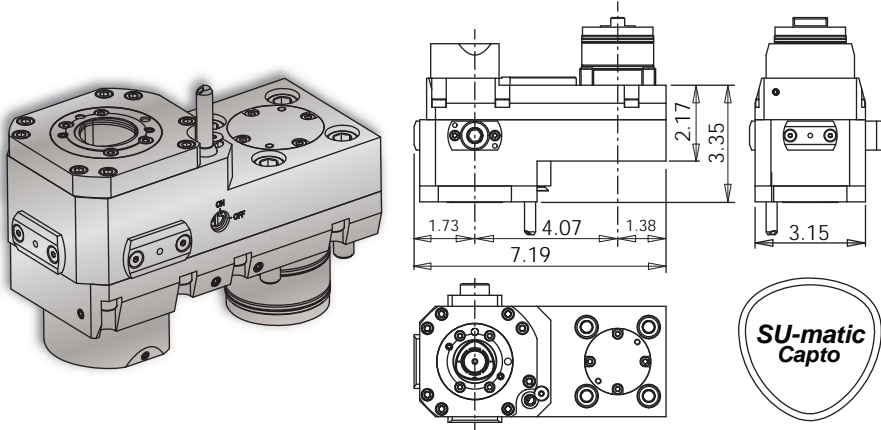

### REGO-FIX® C4 Collet Chucks

ER Output	Rego-Fix Part #
ER-16	2804.11630
ER-20	2804.12010
ER-25	2804.12510
ER-32	2804.13210
Turret Plugs	14.430.0.0207.0

\* 1,000 psi internal coolant (IC) cross tool CANNOT be run without coolant.

All coolant thru live tools require 30 micron coolant filtration nominal, 50 micron coolant filtration absolute.

Tool #	Coolant	Output	Rotation (In:Out)	Ratio (In:Out)	Max. RPM	Torque	Hex Wrench	C4 Collet Chucks
14.101.0.0322.0	IC & EXT* 1,000 psi	C4	CW:CW	1:1	6,000	40 Nm	10 mm	See Above

### 2SP-150HM C4 Face Tool

### Notes

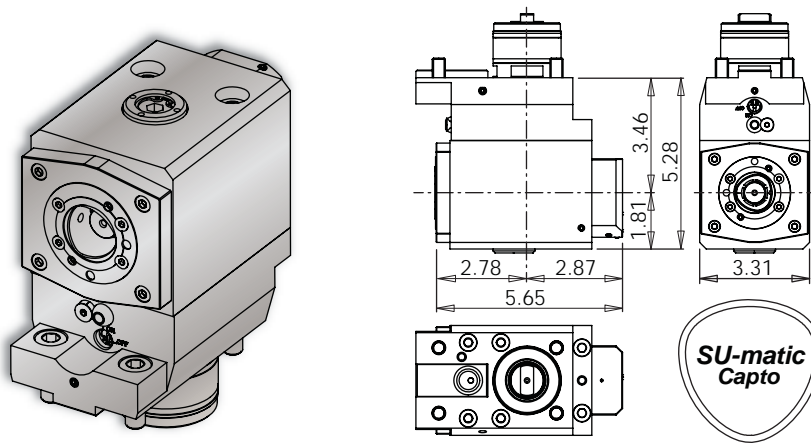

### REGO-FIX® C4 Collet Chucks

ER Output	Rego-Fix Part #
ER-16	2804.11630
ER-20	2804.12010
ER-25	2804.12510
ER-32	2804.13210
Turret Plugs	14.430.0.0207.0

\* 1,450 psi internal coolant (IC) face tool CAN be run without coolant; the coolant sealing mechanism can be completely dis-engaged.

All coolant thru live tools require 30 micron coolant filtration nominal, 50 micron coolant filtration absolute.

Tool #	Coolant	Output	Rotation (In:Out)	Ratio (In:Out)	Max. RPM	Torque	Hex Wrench	C4 Collet Chucks
14.800.0.0437.0	IC & EXT* 1,450 psi	C4	CW:CW	1:1	6,000	40 Nm	10 mm	See Above