

VELOCITY TOOLING FOR OKUMA LT2000 M/MY

Live Tools



LT2000 Dual Output Face Tool (L / R Spindles) • ER-25 Outputs

Notes

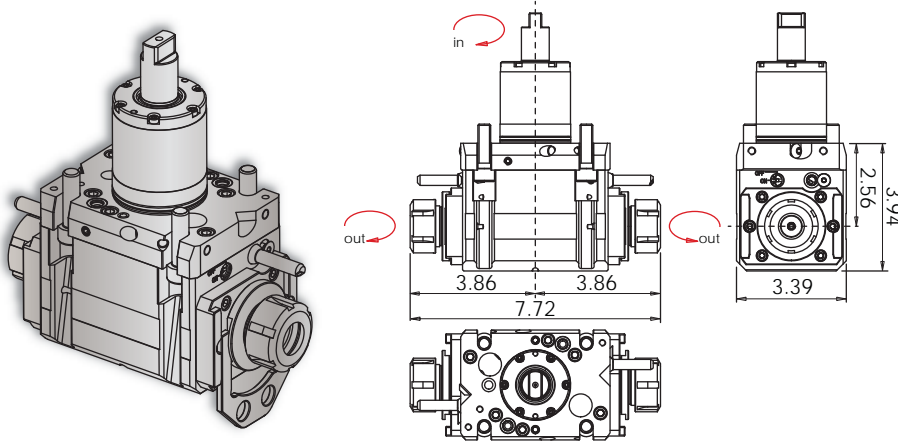

Wrenches Included with Tools

Maximum Drill Ø	Maximum Mill Ø
5/8"	9/16"
Turret Plugs 14.430.0.0088.0	

VELOCITY/SU-matic driven tools are greased for life and delivered ready to use - **no run-in required**. All driven tools are CMM inspected and internal coolant tools are pressure tested as a final quality check prior to shipment.

Tool #	Coolant	Output	Rotation (In:Out)	Ratio (In:Out)	Max. RPM	Torque	Spindle Wrench	Collet Wrench
14.801.0.0124.0 (14.801.0.0083.0)	EXT	ER-25 (2)	See Dwg. Above	1:1	6,000	40 Nm	1005100980	7111.25000

LT2000 ±90° Adjustable Angle Tool • ERAX-16 Output

Notes

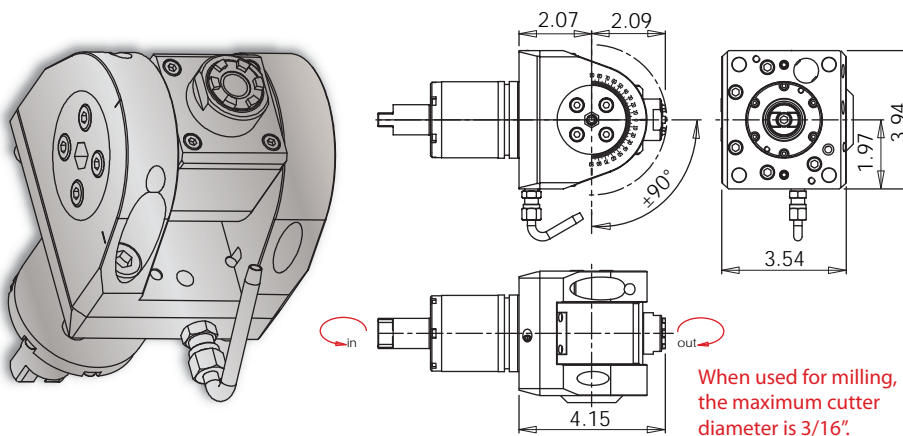

Wrenches Included with Tools

Maximum Drill Ø	Maximum Mill Ø
13/32"	3/16"
Turret Plugs 14.430.0.0088.0	

VELOCITY/SU-matic driven tools are greased for life and delivered ready to use - **no run-in required**. All driven tools are CMM inspected and internal coolant tools are pressure tested as a final quality check prior to shipment.

Tool #	Coolant	Output	Rotation (In:Out)	Ratio (In:Out)	Max. RPM	Torque	Spindle Wrench	Collet Wrench
14.826.0.0018.0	EXT	ERAX-16	CCW: CW	1:1	6,000	15 Nm	26 mm	7117.16000