

# VELOCITY TOOLING FOR OKUMA LU3000 M/MY

## Live Tools



### LU3000 MY Face Tool • ER-25 Outputs

### Notes

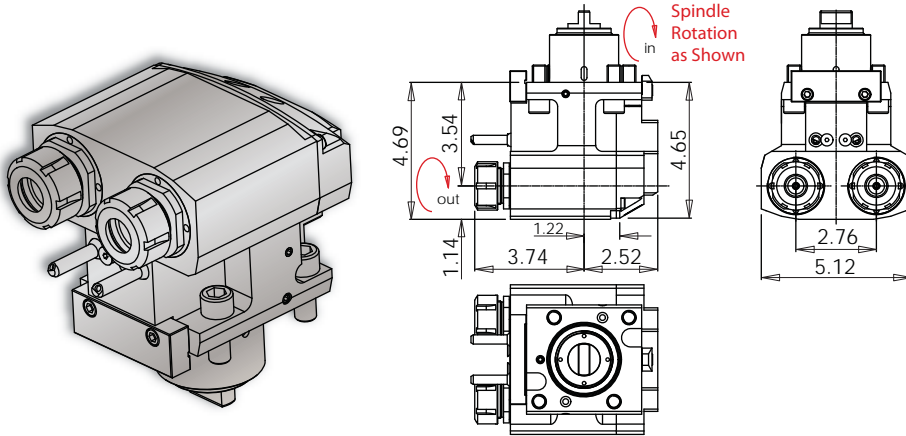

#### Wrenches Included with Tools

Maximum Drill Ø	Maximum Mill Ø
-----------------	----------------

5/8"	17/32"
------	--------

Turret Plugs	14.430.0.0086.0
--------------	-----------------

VELOCITY/SU-matic driven tools are greased for life and delivered ready to use - **no run-in required**. All driven tools are CMM inspected and internal coolant tools are pressure tested as a final quality check prior to shipment.

Tool #	Coolant	Output	Rotation (In:Out)	Ratio (In:Out)	Max. RPM	Torque	Spindle Wrench	Collet Wrench
14.801.0.0115.0	EXT	ER-25	CW:CW	1:1	6,000	25 Nm	40 mm	7111.25000

### LU3000 ±90° Adjustable Angle Tool • ERAX-20 Output

### Notes

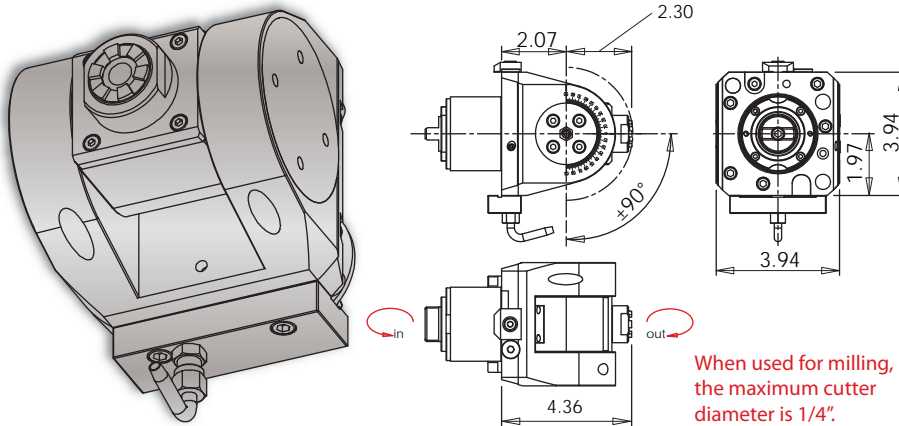

#### Wrenches Included with Tools

Maximum Drill Ø	Maximum Mill Ø
-----------------	----------------

1/2"	1/4"
------	------

Turret Plugs	14.430.0.0086.0
--------------	-----------------

VELOCITY/SU-matic driven tools are greased for life and delivered ready to use - **no run-in required**. All driven tools are CMM inspected and internal coolant tools are pressure tested as a final quality check prior to shipment.

Tool #	Coolant	Output	Rotation (In:Out)	Ratio (In:Out)	Max. RPM	Torque	Spindle Wrench	Collet Wrench
14.826.0.0015.0	EXT	ERAX-20	CCW:CW	1:1	6,000	15 Nm	32 mm	7117.20000