

# VELOCITY TOOLING FOR OKUMA LU3000 M/MY

## SU-matic Capto® Tools

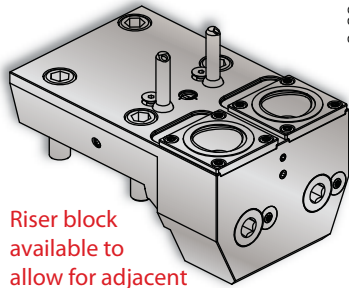

### LU3000 MY C4 Y-Axis OD-I Length Turning Holder



Riser block available to allow for adjacent mounting on turret.  
Part #14.430.0.0200.0

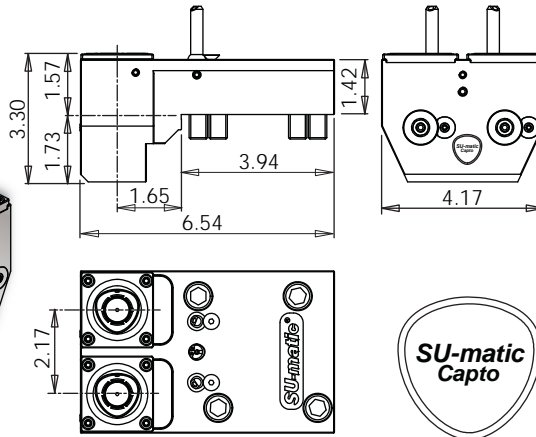

#### Notes

#### REGO-FIX® C4 Collet Chucks

ER Output	Rego-Fix Part #
ER-16	2804.11630
ER-20	2804.12010
ER-25	2804.12510
ER-32	2804.13210

Turret Plugs 14.430.0.0086.0

VELOCITY/SU-matic tooling for OKUMA is manufactured on OKUMA machine tools.

SU-matic Capto® static tools are coolant thru. Coolant filtration is recommended.

Lathe Model	Tool #	Reversible (Main/Sub)	Coolant	Output	Hex Wrench	C4 Collet Chucks
LU3000 MY	14.910.0.0118.0	No	IC/EXT	(2) C4	10 mm	See Above

### LU3000 C4 Boring Bar Holder

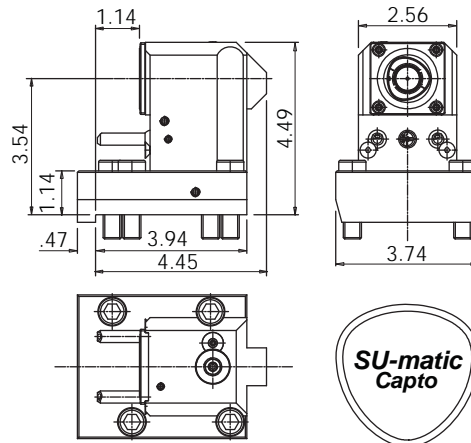
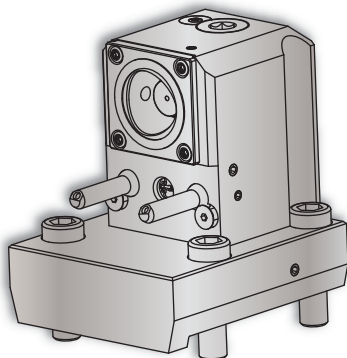

#### Notes

#### REGO-FIX® C4 Collet Chucks

ER Output	Rego-Fix Part #
ER-16	2804.11630
ER-20	2804.12010
ER-25	2804.12510
ER-32	2804.13210

Turret Plugs 14.430.0.0086.0

VELOCITY/SU-matic tooling for OKUMA is manufactured on OKUMA machine tools.

SU-matic Capto® static tools are coolant thru. Coolant filtration is recommended.

Lathe Model	Tool #	Reversible (Main/Sub)	Coolant	Output	Hex Wrench	C4 Collet Chucks
LU3000 M	14.910.0.0237.0	Yes	IC/EXT	C4	10 mm	See Above