

## Static Tools

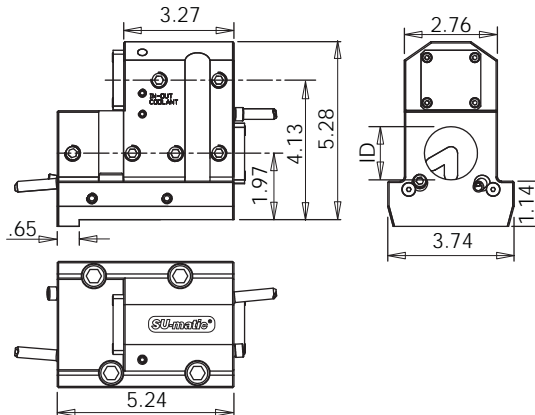

### LB3000 Boring Bar Holder • Main/Sub Spindle

### Notes

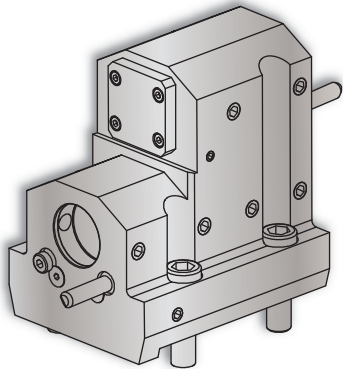

*VELOCITY/SU-matic* ID holders can be used with both internal and external coolant. Internal Coolant Plates are included with all *VELOCITY/SU-matic* multitasking turret ID holders.

Turret Plugs	14.430.0.0086.0
--------------	-----------------

*VELOCITY/SU-matic* tooling for OKUMA is manufactured on OKUMA machine tools.

Coolant filtration is recommended when using ID holders with internal coolant plates.

Lathe Model	Tool #	Reversible (Main/Sub)	Coolant	ID Top	ID Bottom	Height
LB3000 MYW	14.910.0.0211.0	-	IC/EXT	1.5"	1.5"	5.28"

### LB3000 MY/MYW Quad Boring Bar Holder

### Notes

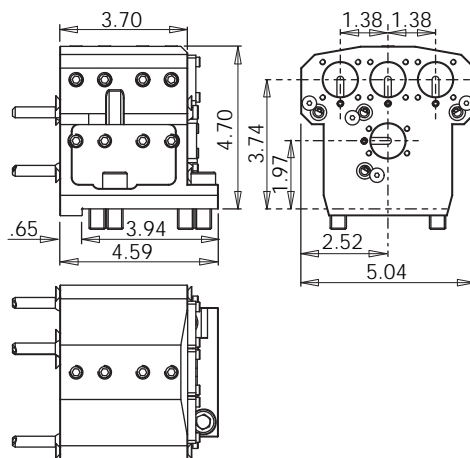
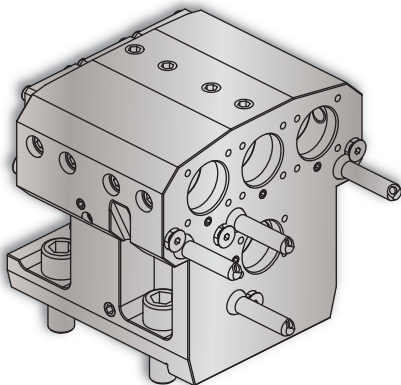

*VELOCITY/SU-matic* ID holders can be used with both internal and external coolant. Internal Coolant Plates are included with all *VELOCITY/SU-matic* multitasking turret ID holders.

Turret Plugs	14.430.0.0086.0
--------------	-----------------

*VELOCITY/SU-matic* tooling for OKUMA is manufactured on OKUMA machine tools.

Coolant filtration is recommended when using ID holders with internal coolant plates.

Lathe Model	Tool #	Reversible (Main/Sub)	Coolant	ID	Height	Depth
LB3000 MY	14.910.0.0363.0	No	IC/EXT	1.0" x (4)	4.70"	4.59"