

VELOCITY TOOLING FOR OKUMA LU3000 M/MY

SU-matic Capto® Tools

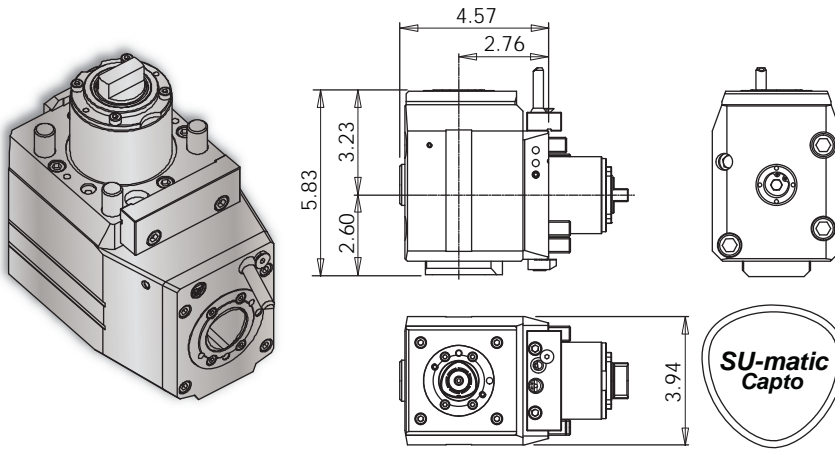

LU3000 C4 Face Tool



Notes

REGO-FIX® C4 Collet Chucks

ER Output	Rego-Fix Part #
ER-16	2804.11630
ER-20	2804.12010
ER-25	2804.12510
ER-32	2804.13210

Turret Plugs 14.430.0.0086.0

* 1,450 psi internal coolant (IC) face tool **CAN** be run without coolant; the coolant sealing mechanism can be completely dis-engaged.

All coolant thru live tools require 30 micron coolant filtration nominal, 50 micron coolant filtration absolute.

Tool #	Coolant	Output	Rotation (In:Out)	Ratio (In:Out)	Max. RPM	Torque	Hex Wrench	C4 Collet Chucks
14.800.0.0233.1	IC & EXT* 1,450 psi	C4	CW:CW	1:1	6,000	60 Nm	10 mm	See Above

LU3000 C4 OD-I Length Turning Holder

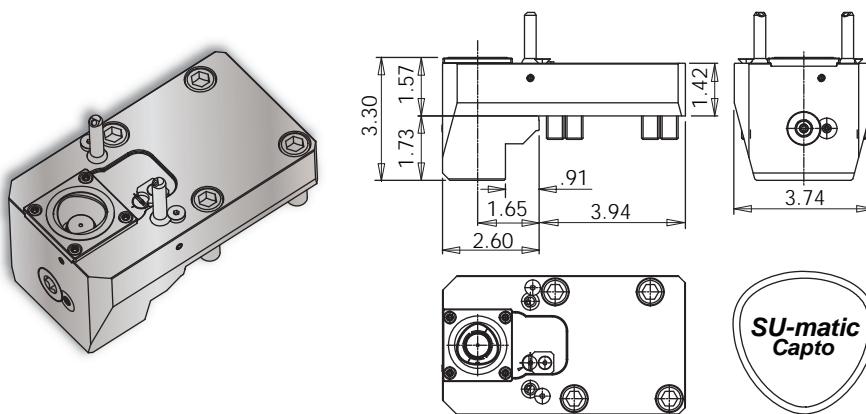

Notes

REGO-FIX® C4 Collet Chucks

ER Output	Rego-Fix Part #
ER-16	2804.11630
ER-20	2804.12010
ER-25	2804.12510
ER-32	2804.13210

Turret Plugs 14.430.0.0086.0

VELOCITY/SU-matic tooling for OKUMA is manufactured on OKUMA machine tools.

SU-matic Capto® static tools are coolant thru. Coolant filtration is recommended.

Lathe Model	Tool #	Reversible (Main/Sub)	Coolant	Output	Hex Wrench	C4 Collet Chucks
LU3000 M	14.910.0.0239.0	No	IC/EXT	C4	10 mm	See Above