

VELOCITY TOOLING FOR OKUMA LT2000 M/MY

SU-matic Capto® Tools

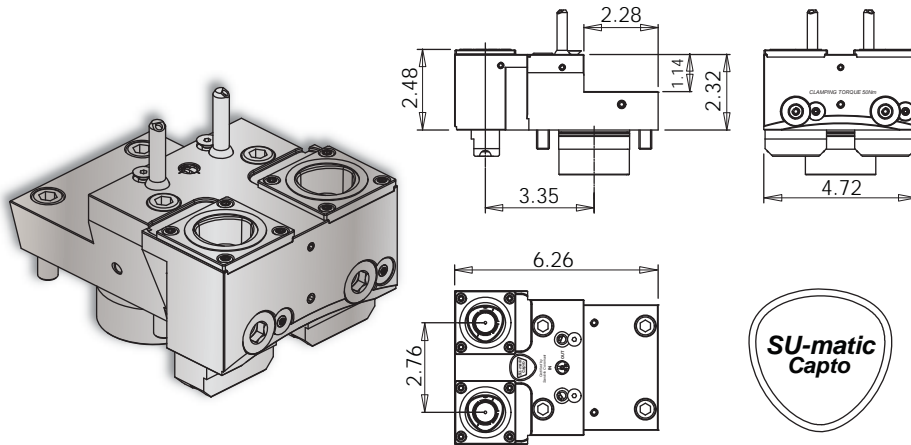

LT2000 C4 OD-I-S Y-Axis Length Turning Holder



Notes

REGO-FIX® C4 Collet Chucks

ER Output	Rego-Fix Part #
ER-16	2804.11630
ER-20	2804.12010
ER-25	2804.12510
ER-32	2804.13210

Turret Plugs 14.430.0.0088.0

VELOCITY/SU-matic tooling for OKUMA is manufactured on OKUMA machine tools.

SU-matic Capto® static tools are coolant thru. Coolant filtration is recommended.

Lathe Model	Tool #	Reversible (Main/Sub)	Coolant	Output	Hex Wrench	C4 Collet Chucks
LT2000	14.910.0.0265.0	Yes	IC/EXT	C4	10 mm	See Above

LT2000 C4 Boring Bar Holder

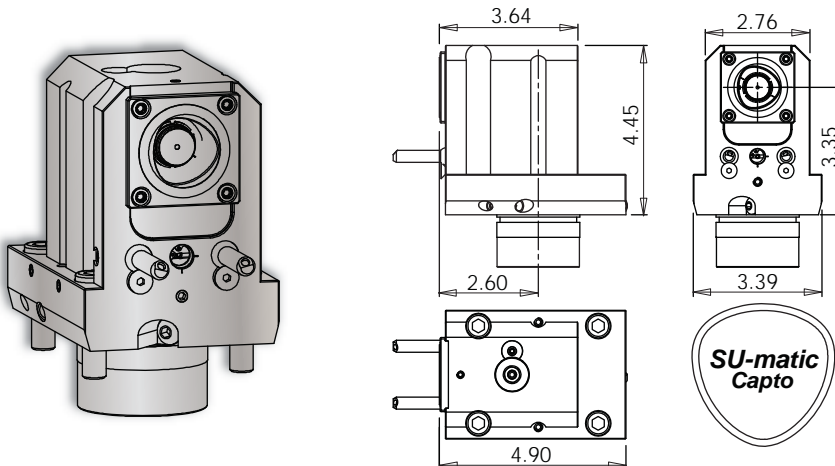

Notes

REGO-FIX® C4 Collet Chucks

ER Output	Rego-Fix Part #
ER-16	2804.11630
ER-20	2804.12010
ER-25	2804.12510
ER-32	2804.13210

Turret Plugs 14.430.0.0088.0

VELOCITY/SU-matic tooling for OKUMA is manufactured on OKUMA machine tools.

SU-matic Capto® static tools are coolant thru. Coolant filtration is recommended.

Lathe Model	Tool #	Reversible (Main/Sub)	Coolant	Output	Hex Wrench	C4 Collet Chucks
LT2000	14.910.0.0110.0	Yes	IC/EXT	C4	10 mm	See Above