

LB35III/LU35II "L" Turret Holders

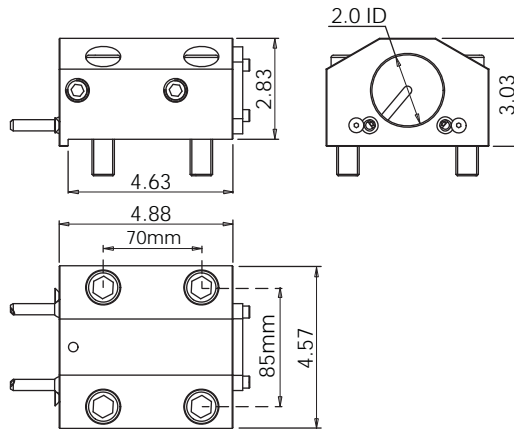

ID Holder for LB35III • LU35II

Notes

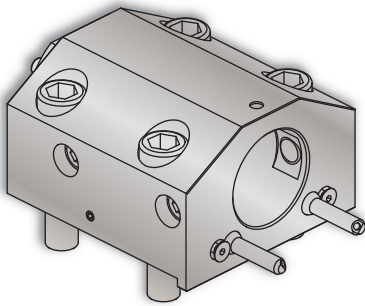

VELOCITY/SU-matic ID holders can be used with both internal and external coolant. **Internal Coolant Plates** are included with all *VELOCITY/SU-matic* multitasking turret ID holders.

VELOCITY/SU-matic tooling for OKUMA is manufactured on OKUMA machine tools.

Coolant filtration is recommended when using ID holders with internal coolant plates.

Lathe Model	Tool #	Reversible (Main/Sub)	Coolant	ID	Height	Depth
LB35III • LU35II	14.910.0.0309.0	-	IC/EXT	2.0"	3.03"	4.88"

OD-I Holder for LB35III • LU35II

Notes

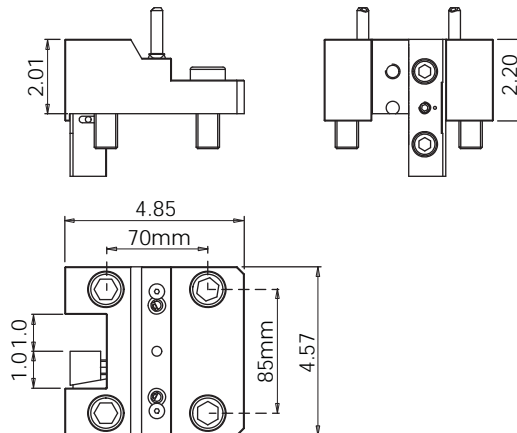
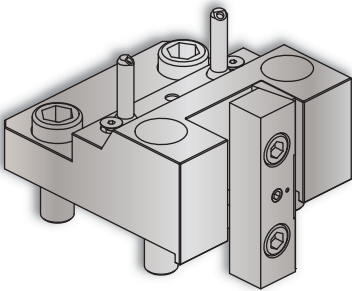

3D Models (.stp) and CAS (.stl) files are available for all *VELOCITY/SU-matic* tool holders. Please contact Velocity: sales@velocityproducts.com.

VELOCITY/SU-matic tooling for OKUMA is manufactured on OKUMA machine tools.

VELOCITY has the most complete inventory of tooling for OKUMA machine tools in North America.

Lathe Model	Tool #	Reversible (Main/Sub)	Stick Size	Mounting Bolt Centers	Height	Depth
LB35III • LU35II	14.910.0.0310.0	No	1.0"	70mm x 85mm	2.01"	4.85"